

ASPECTS OF THE INTERNAL STRUCTURE OF NOMINALIZATION: ROOTS,
MORPHOLOGY AND DERIVATION

by

Jeffrey Punske

A Dissertation Submitted to the Faculty of the

DEPARTMENT OF LINGUISTICS

In Partial Fulfillment of the Requirements
For the Degree of

DOCTOR OF PHILOSOPHY

In the Graduate College

THE UNIVERSITY OF ARIZONA

2012

THE UNIVERSITY OF ARIZONA
GRADUATE COLLEGE

As members of the Dissertation Committee, we certify that we have read the dissertation prepared by Jeffrey Punske entitled Aspects of the internal structure of nominalization: roots, morphology and derivation and recommend that it be accepted as fulfilling the dissertation requirement for the Degree of Doctor of Philosophy

_____ Date:6/30/11
Simin Karimi

_____ Date: 6/30/11
Heidi Harley

_____ Date:6/30/11
Andrew Carnie

_____ Date:6/30/11
Andrew Barss

_____ Date:6/30/11
Richard Larson

Final approval and acceptance of this dissertation is contingent upon the candidate's submission of the final copies of the dissertation to the Graduate College. I hereby certify that I have read this dissertation prepared under my direction and recommend that it be accepted as fulfilling the dissertation requirement.

_____ Date: 6/30/11
Dissertation Director: Simin Karimi

STATEMENT BY AUTHOR

This dissertation has been submitted in partial fulfillment of requirements for an advanced degree at the University of Arizona and is deposited in the University Library to be made available to borrowers under rules of the Library.

Brief quotations from this dissertation are allowable without special permission, provided that accurate acknowledgment of source is made. Requests for permission for extended quotation from or reproduction of this manuscript in whole or in part may be granted by the author.

SIGNED: Jeffrey Punske

ACKNOWLEDGMENTS

A dissertation is not a work of individual effort. Though, only my name is listed as an author, there are so many other people who have contributed to this work directly or indirectly and supported me in the ways that made it possible. These pages are an attempt to acknowledge and thank those people, though understand it is impossible to list everyone or to thank those listed enough.

I would like to begin by thanking the graduate students (present and past), staff and professors in the Department of Linguistics at the University of Arizona. All of you have been my family for the last several years. In particular I would like to thank, in no particular order, Simin Karimi, Heidi Harley, Andrew Carnie, Andy Barss, Adam Ussishkin, Amy Fountain, Mike Hammond, Diana Archangeli, Cecil McKee, Diane Ohala, Mary Willie, Ofelia Zepeda, Janet Nicol, Natasha Warner, Andy Wedel, Tom Bever, Massimo Piattelli-Palmarini, Amy LaCross, Lindsay Butler, Jessamyn Schertz, Dan Siddiqi, Scott Jackson, Maggie Camp, Dave Mederios, Jeff Witzel, Leila Lomashvili, Bob Kennedy, Michael Anderson, Mans Hulden, Carly Tex, Jordan Brewer, Erin Good, Polly O'Rourke, Sumayya Racy, Peter Richtsmeier, Yosuke Sato, Angelina Serratos, Shannon Bischoff, Cathy Hicks-Kennard, Alina Twist, Jason Haugen, Erin O'Bryan, Colleen Fitzgerald, Gregory Anderson, Dane Bell, Rolando Soto, Andréa Davis, Jeff Berry, Dan Brenner, Ethan Dickinson, Emma Ehrhart, Julia Fischer, Kara Hawthorne, Colin Gorrie, Alan Hogue, Alex Trueman, Elly Zimmer, Samantha Wray, Miriam Diaz, Mercedes Tubino, Brecht Welch, Maureen Hoffman, Keisha Josephs, Hyung Kyoung Jung, Greg Key, Emily Kidder, Kenne Likkel, Lio, Mathieu, Jorge Muriel, Jaime Parchment, Jaehoon Choi, Kevin Schluter, Megan Stone, Jae-Hyun Sung, Deniz Tat and Sylvia Reed. I discuss many of these individuals in more detail. But I wanted to provide such a long list here to illustrate my point of how this is not an individual effort. And this is but a mere subset of the total people involved.

I would be extremely remiss to forget to mention Marian Wisely, Jennifer Columbus and Kimberly Young. Marian is a source of light and joy in the department. She can almost always be counted on to cheer you up when you are down or to knock you down a peg when you are getting too high on yourself. She's great. She's always ready to go to bat for you and she's an endless source of knowledge and spirit. Kimberly is a rock star. She's helpful and joyful in what she does.

Through this all, I owe most of this work to Simin Karimi, my far too gracious advisor. Simin has stood by me as I struggled to precisify a dissertation topic. She helped me manage to process of going from the dissertation that I thought I wanted to write into the dissertation that I actually wanted to write. She is funny. She is kind. She is prompt. One would be hard pressed to find a better advisor.

In many ways, Heidi Harley was advisor B. In many ways this work most closely reflects my vision of Heidi's work. This was quite the transition for me. I entered into

Heidi's morphology and lexical semantics classes highly resistant to idea that Distributed Morphology had much going for it. Now, I have written a dissertation in that framework. I view that as a testament to Heidi as a teacher and as a scholar. But Heidi is so much more than that, she is truly a person to be admired. Despite all of her brilliance and all of the amazing work she does, she finds time for all of her students and she finds time to have fun. Occasionally, she even finds time to truck across the galaxy with me. Go get'em, Big Rig!

Andrew Carnie might be the single most important person in my education as a linguist. Andrew was my mentor through my undergraduate years and he was the person who pushed me the most during my graduate years. Andrew is exacting and honest. He is the perfect mentor. Besides being a great professor, mentor and colleague, I like to consider Andrew a friend. Andrew certainly helped feed my board gaming addiction which was absolutely necessary for my survival in grad school.

Andy Barss is a legend. Working with Andy is an amazing experience. The wealth of knowledge that he holds is probably unparalleled in the field. I truly believe this. His ability to recall critical arguments from obscure sources and blend them into a coherent theoretic picture is a sight that must be seen to be believed. Whenever I was stuck on a particular jarring issue, I'd always go to Andy. Without exception, Andy would set me on the course that find the answer.

Richard Larson was my most challenging committee member (and I mean this in a very good way). Never would he let me get away with a theoretic assumption for the sake of the analysis, he pressed me very hard. He made me a better-rounded linguist. It was truly a privilege and an honor to get the opportunity to work with him.

All together, my committee formed an amazing team. Whenever I am asked, "who was your advisor?" I, of course, say Simin but often I feel the need to say that I really had a whole committee working for me. Every single member of my committee went well above the call of duty for me. Everyone one of them deserves every ounce of gratitude I can offer. When I'm asked next who my advisor was, I might offer this as a response: "Larson-Barss-Carnie-Harley with Simin Karimi leading the charge."

Outside of my committee members there are several faculty members I need to thank for their individual efforts. First, there is Adam Ussishkin who led me through the undergraduate-to-graduate transition and taught me a lot about how to be a professional linguist. Amy Fountain who taught me how to blend teaching and research and gave me a sounding board and a cookie whenever times were tough. Mike Hammond who taught me how to find balance. Diana Archangeli who taught me how to be a professional. Diane Ohala whose unrelenting kindness was always a joy and who gave me the space I needed to get this work done. And finally, Natasha Warner who taught me how to balance my teaching and service needs with my research. There are many others who did

many things along the way. I wish I could list them all but this acknowledgment section is already pushing the bounds of tastefulness.

The students who have inspired or helped me are simply too numerous to fully list. As with above, I will list many, but understand that this list is incomplete. It would be egregious for me not to list Amy LaCross here. I know that many of the linguists have gotten immense joy from hearing Amy and I bicker as if we were 8 year-old siblings, or 75 year-old spouses. Essentially, we are both. More than anyone else, Amy feels like family. She's seen me at my worst and still stood by me. Yosuke Sato has always been an inspiration to me. I wish I had his drive. He is a friend who kept me focused on what I needed to do next. Scott Jackson has been my guide through much of my graduate career. Whenever I was stuck I knew I could turn to Scott. Sylvia Reed has been my office-mate, frenemy, friend, and many other roles. She drove me through my last year. Lindsay Butler has been a complicated but inspiring figure to me. We have struggled together almost always at the same time. She has always been there to pull me out. Jessamyn Schertz's no nonsense attitude was critical for me when I got stuck in a rut. I knew that if I wasn't working, she'd say whatever I need to make the "justifications" go away. And, that if I really just couldn't get stuff done that day, she'd be over to play Dominion.

I would be remiss to not thank everyone who has listened to me speak at various venues and given me critical feedback that informs much of the work in this dissertation. There are simply too many conferences and individuals to thank here. But I would like to give a special acknowledgment to the audience of the 2009 Mid-American Linguistics Conference where the kernel that forms the bulk of this dissertation was first conceived. I also need a place to thank Mike Putnam, who I met there.

There are many other people who I need to thank outside whose roles were largely outside of my academic development but no doubt were a major part of it. First, my parents-- for obvious reasons that I do not have the space to enumerate. Heather Jackson who took in whatever crazy I was spewing that day and turned it into something understandable. There were times when Heather felt like my life jacket is a vast sea of linguistic theory. John Ivens and all of the hikers for getting me outdoors and reminding me that one cannot have a healthy mind while one is trapped indoors all the time. Maggie Camp and James Garza who provided much needed silliness in a world that is all together too serious. The gamers (who somewhat sadly, but all together too predictably are too numerous to name individually) who gave my mind some other puzzles to solve—which opened it to solving the ones in here. And to the people at The Ultima who by training my body allowed my mind to open up and finish this thing. I also owe an incredible debt to "the writers/crocheters" who not only taught me the art of Keith-Fu (thank you, Mr. Martin) but kept me in touch with perspectives outside of linguistics and kept the world a fun place. Also, they usually kept me well fed and well boozed.

I know that I have forgotten someone or something. For that I apologize.

DEDICATION

To my parents.

TABLE OF CONTENTS

| | |
|---|----|
| LIST OF FIGURES..... | 12 |
| LIST OF TABLES..... | 13 |
| ABSTRACT..... | 14 |
| CHAPTER 1 INTRODUCTION..... | 16 |
| 1.1 Goals of the Dissertation..... | 16 |
| 1.2 Specific Goals of this Chapter..... | 17 |
| 1.2.1 Major Assumptions..... | 18 |
| 1.2.1.1 Distributed Morphology..... | 18 |
| 1.3 Parallelism: What is it? And What's Wrong with it?..... | 20 |
| 1.3.1 Parallelist Hypothesis- Strong Form..... | 22 |
| 1.3.2 Parallelist Hypothesis- Weak Form | 22 |
| 1.3.3 The Anti-Parallelist Hypothesis..... | 23 |
| 1.4 Cartography..... | 24 |
| 1.5 Form Identity and Labeling..... | 27 |
| 1.6 Outline of the Dissertation..... | 31 |
| CHAPTER 2 NOMINALIZATION AND OBJECTS..... | 34 |
| 2.1 Introduction..... | 34 |
| 2.1.1 Organization of the Chapter..... | 35 |
| 2.2 Gerunds..... | 35 |
| 2.2.1 An Aside on Terminology..... | 36 |
| 2.2.2 True Gerunds..... | 38 |

TABLE OF CONTENTS -- CONTINUED

| | |
|--|----|
| 2.2.3 Nominal Gerunds..... | 40 |
| 2.3 Binding and the Derivation of Nominals..... | 45 |
| 2.4 “Object Arguments” of Nominal Gerunds as Adjuncts: C- Command..... | 52 |
| 2.5 “Object Arguments” of Nominal Gerunds as Adjuncts: Semantic Interpretations..... | 53 |
| 2.6 “Object Arguments” of Nominal Gerunds as Adjuncts: Resultatives..... | 56 |
| 2.7 Derived Nominals..... | 58 |
| 2.8 The Location of the Derivation..... | 62 |
| 2.9 Conjunction..... | 71 |
| 2.10 A Brief Aside on the Nature of the Contrast..... | 73 |
| 2.11 Object Opaqueness..... | 74 |
| 2.12 Negative Polarity and “Action Nominals”..... | 76 |
| 2.13 Conclusions..... | 78 |
| CHAPTER 3 THAT DEPENDS ON WHAT THE MEANING OF OF IS..... | 80 |
| 3.1 Goals..... | 80 |
| 3.2 <i>of</i> in Previous Accounts..... | 81 |
| 3.2.1 The Model..... | 82 |
| 3.2.2 <i>of</i> as Inherent Case-Marker..... | 84 |
| 3.2.3 Consequences..... | 85 |
| 3.3 Problems for Sproat (1985)..... | 85 |
| 3.3.2 Empirical Issues..... | 85 |
| 3.4 Modernizing the Account..... | 87 |

TABLE OF CONTENTS -- CONTINUED

| | |
|--|-----|
| 3.4.1 Tests for Different Types of <i>of</i> | 87 |
| 3.4.2 Basics of the Analysis..... | 88 |
| 3.4.3 Extraction and Pied Piping..... | 93 |
| 3.4.4 Conjunction and the Structural Order of <i>nP</i> and <i>kP</i> | 96 |
| 3.5 DM and <i>of</i> | 101 |
| 3.5.1 When in Doubt, Insert <i>of</i> | 102 |
| 3.5.2 <i>of</i> and Case..... | 103 |
| 3.5.3 A Tentative Feature Break-Down of English Prepositions..... | 104 |
| 3.6 Conclusions..... | 105 |
| CHAPTER 4 EXPLAINING AWAY <i>EXPLAIN AWAY</i> | 107 |
| 4.1 Introduction..... | 107 |
| 4.2 The Trouble with <i>explain away</i> | 109 |
| 4.3 <i>away</i> as a Small Clause Particle and as a Non-Small Clause Particle..... | 117 |
| 4.3.1 <i>away</i> as a Small Clause Particle..... | 117 |
| 4.3.1.1 <i>away</i> as a True Particle..... | 118 |
| 4.3.1.2 Other Uses of <i>away</i> | 118 |
| 4.3.1.3 <i>away</i> with Latinates..... | 119 |
| 4.3.2 <i>away</i> is not a (True) Particle (when with Latinates)..... | 121 |
| 4.4 The Structure of English Verb Particle Constructions..... | 123 |
| 4.5 Unselected Objects: Temporal <i>away</i> and Complex Head Particle Constructions..... | 131 |
| 4.6 Restricting the Size of the Verbal Domain..... | 133 |

TABLE OF CONTENTS – CONTINUED

| | |
|---|------------|
| 4.7 Conclusions..... | 134 |
| CHAPTER 5 MORPHOLOGICAL CONSPIRATORS: MORPHO-SYNTAX AND THE APPARENT EVENT-STRUCTURE DIFFERENCES ACROSS FORMS OF NOMINALIZATION..... | 136 |
| 5.1 Introduction..... | 136 |
| 5.1.1 Problems for the Accounts Offered in this Dissertation..... | 138 |
| 5.1.2 Derived Nominals and Morphology..... | 139 |
| 5.2 A Typology of Particles, Arguments and Nominalization..... | 141 |
| 5.3 Morphology Nominalization and Particles..... | 143 |
| 5.3.1 Harley 2008 Revisited..... | 144 |
| 5.3.2 Distributed Morphology, the Mirror Principle and Particle Incorporation..... | 148 |
| 5.3.3 Non-Latinate Derived Nominals..... | 153 |
| 5.4 Conclusion..... | 154 |
| CHAPTER 6 CONCLUSIONS..... | 157 |
| 6.1 Notes for the Future..... | 158 |
| 6.1.1 Verbal Gerunds..... | 158 |
| 6.1.2 Aspect, Nominalization and Morphological Identity..... | 159 |
| 6.1.3 Regularity..... | 160 |
| REFERENCES..... | 161 |

LIST OF FIGURES

| | |
|--|-----|
| Figure 3-1 Government and Binding Model..... | 83 |
| Figure 6-1 Typology of Nominalization | 157 |

LIST OF TABLES

| | |
|--|----|
| Table 1-1 Syncretism in verbal and nominal suffixes..... | 29 |
| Table 1-2 Syncretism in determiners and complementizers..... | 30 |
| Table 2-1 Terminology associated with nominalization..... | 38 |

ABSTRACT

This dissertation uses syntactic, semantic and morphological evidence from English nominalization to probe the interaction of event-structure and syntax, develop a typology of structural complexity within nominalization, and test hypotheses about the strict ordering of functional items. I focus on the widely assumed typology of nominalization found in Chomsky (1970). In particular, I show that derived nominals are structurally more complex than nominal gerunds; this has long been assumed to be the opposite.

I provide a structural and morphological account of these forms of nominalization. In doing so, I explore a number of disparate topics such as: the importance of syncretism in apparently unrelated morphological elements for theories like Distributed Morphology; the role of prepositions in allowing or preventing binding relations and NPI-licensing, the exact nature of root-object union that allows idiomatic interpretations; the morphological reflexes of Case in the nominal system; the syntactic structure of verb particle constructions; the nature of events in nominalization; and the role syntactic operations play in determining morphological regularity.

The dissertation also explores the nature of the English verb particle construction, arguing that it has (at least) three distinct structural configurations. Using these three distinct structures I am able to explain a number of distinct behaviors from predicate-object relationships, particle modification and argument loss in particle construction.

I also discuss the relationship between particles (and results) and the different forms of nominalization. In particular, I show that apparent co-occurrence restrictions

between nominal types and particles are not due to event-structure or other semantic restrictions. Rather, these differences are tied solely to the particular, idiosyncratic morphological properties of the constructions.

The dissertation shows that certain functional projections may only appear once with a given root, but that there is some freedom of ordering of projections relative to the root in some cases. This work provides a window into the interaction between syntax and event structure as well as the nature of ordering within functional projections.

CHAPTER 1: INTRODUCTION

1.1. Goals of the Dissertation

In this work, I investigate the behavior of English nominalization with respect to a number of different linguistic behaviors: event structure, idiomatization,, morphological regularity, argument structure and so forth. Perhaps the most interesting and compelling aspect of this work is that a long-held view of the structural/lexical complexity of English nominalization appears to be wrong; since at least Chomsky (1970), linguists have assumed that derived nominalization is structurally less complex or equivalent to nominal gerunds (aka mixed nominalization). I show that nominal gerunds are less complex.

Ultimately, the goal of this dissertation is to explore the structure of nominal phrases. In particular, I concern myself with nominalization, but in doing so present an indirect series of arguments against the strong form of the CP-DP Parallelist Hypothesis. The details of this hypothesis and some objections to it are sketched out in this chapter.

At its core the arguments presented in this dissertation are that roots (which ultimately are predicates) enter the derivation impoverished and require functional heads to receive certain interpretive effects, to license arguments, etc. As we will see, this fact alone is enough to explain many of the effects attributed to Parallelism/Cartography. Critically, I show that these functional heads are not universally present in nominals. Without universality, Parallelism falls flat.

The lack of universality is shown by the failure of English nominal gerunds to fully license arguments and to participate in idiomization is taken as evidence of

impoverished functional structure. The nature of this functional structure and the consequence of its absence drive this dissertation.

1.2 Specific Goals of this Chapter

This chapter is meant as an outline of the assumptions made within this dissertation, a preliminary discussion of the Parallelist Hypothesis and its various forms and discussion of some objections to it, and as a roadmap for the dissertation itself.

To complete the first goal, the chapter begins with discussion of the major assumptions and theoretical background that makes up the backbone of this dissertation. This discussion includes discussion of Distributed Morphology (henceforth DM) (Halle and Marantz 1993) and the Minimalist Program (Chomsky 1993/1995a and subsequent).

The second goal outlines the basic assumptions of a Parallelist Hypothesis. It includes discussion of overlap of assumptions between parallelist work and this dissertation. While this dissertation is meant as an argument against the strong form of this hypothesis, the dissertation itself could be characterized as the weakest form of the hypothesis. That is to say that this dissertation does not argue against the presence of *any* overlap between the DP and CP. Indeed, I assume that the same grammatical constraints that operate in the DP operate in the CP, i.e., there is nothing that unites the DP and CP to the exclusion of other XPs in terms of special rules for syntactic structure building. The differences lie in the structural organization (the presence or absence of certain functional heads) and the needs of the contained elements. The former is the major difference between this work and the strong form of the Parallelist Hypothesis. This chapter also

includes a brief discussion of a strong-form of an anti-Parallelist Hypothesis. To my knowledge, no one has advocated for such an approach and it will be quickly dismissed.

Finally, the chapter concludes with a description of what's ahead. Each subsequent chapter will be introduced and briefly described.

1.2.1 Major Assumptions

This work is heavily grounded in a Chomskyan generative grammar approach—specifically the Minimalist Program (Chomsky 1993/1995a and subsequent). The major assumption of this approach is that language (specifically syntax) is an “optimal solution” to the necessary interface(s) of the Conceptual-Intensional system and motor-processing systems. This is accomplished through the notion of derivation by least effort. In other words, the grammar is lazy. Within this larger framework there are a number of differing formulations and implementations. I will discuss the major ones that are used in this dissertation.

1.2.1.1 Distributed Morphology

DM is a late-insertion model. Only after all of the syntactic computations have been done do lexical items get inserted into the structure. This framework is in opposition with lexicalist approaches, which build words in a different part of the grammar separate from the syntax which are then inserted directly in the syntax at the start of the derivation. Chomsky (1970) is one of the most famous lexicalist proposals, and a non-lexicalist approach to similar facts forms the basis of chapter 2.

This model provides us with a number of advantages over lexicalist approaches by putting all of the derivation in a single module. In a purely lexicalist account, most

morphology must precede the syntax (this is especially true of derivational morphology) (a major point in Chomsky (1970)). This creates two grammatical modules that essentially do the same thing: namely, build hierarchical structure. This fundamentally goes against the least effort/optimal solution assumption. By combining the morphology with the syntax this problem is removed.

Within DM, phonological exponents (termed vocabulary items, henceforth VIs) are in competition for insertion after Spell Out. The tool of DM most relevant to this dissertation is the Subset Principle (Halle 1997). The Subset Principle is a constraint on vocabulary insertion¹ which states:

- A Vocabulary Item X is inserted into node² Y iff
- (i) X contains the largest subset of the features³ of Y of all possible candidates
 - (ii) X contains no features not present in Y

Because of this principle the morphological system defines the best fit as a vocabulary item that has the most specified features without having any additional features not specified by the syntax. This system allows for the explanation of syncretisms across various lexical forms. If two distinct terminal nodes share the appropriate features and there isn't a better fit the same morpheme will be inserted. DM (like many other realizational morphological theories) typically tries to reduce morphological identity to featural identity—avoiding any “accidental” homophony. Accidental homophony is defined as two VIs which are (morphologically) identical but

¹ A Vocabulary Item is the phonological content inserted into a syntactic node.

² A syntactic terminal node.

³ Features are associated with both terminal nodes and Vocabulary Items. The correspondence between features in terminal nodes and in the Vocabulary Items determines which VI is inserted.

whose insertion is conditioned by different syntactic features. Put in its strongest terms, this means the default assumption is all form-identical VIs are also featurally identical.

A number of different mechanisms can effect the outcome of Vocabulary Insertion. Most morphemes that occur repeatedly in a syncretism pattern are largely underspecified for features making them an ideal elsewhere candidate. Morphemes that occur rarely are highly specified. Impoverishment (Halle and Marantz, 1993) (the removal of a feature from a node) is another common mechanism, but is largely undiscussed in this work. Similarly, fission (splitting syntactic nodes) and fusion (combing syntactic nodes) can affect the appearance of a given morph, but will not be discussed in this work.

However, the strength of the prohibition against accidental homophony is something that needs both conceptual and empirical consideration. A common theme in this dissertation is that the complete avoidance of homophony is untenable empirically and unnecessary conceptually. That is not to say that the theorist should not attempt to avoid accidentally homophonous elements, but rather when all else is equal if the simpler solution in some other sense requires invoking “accidentally” homophonous elements then the theorist should adopt that solution. Further discussion of this is found later in this chapter.

1.3 Parallelism: What is it? And What’s Wrong with it?

Parallelist approaches to syntax cover a wide-range of disparate views related to the supposed overlapping structure between the Determiner Phrase (DP) and the

Complementizer Phrase (CP) (see: Abney 1987; Szabolcsi 1989,1991; Siloni 1990; Cinque 1994, Hiraiwa 2005)

At its most extreme, this approach advocates for a view that holds that CPs and DPs are not distinct in any way. Roughly speaking, under this view (see for example , Hiraiwa's (2005) Supercategorial Theory of the CP/DP Symmetry), the labels CP and DP are misleading. C and D are not distinct categories and thus their projections are not distinct. For Hiraiwa, DP and CP are differentiated post-transfer. Category is determined by the insertion of a valued [N] feature post transfer. If the feature is positively valued then the category D is assigned; if the feature is negatively valued the category is C.

It is possible to take this view even farther. Instead of introducing categories post-transfer, we could assume that D and C are categorically identical. Such a view is often hinted at in the literature, but to my knowledge remains unformalized. Felix (1988) notes that some constructions in German and Spanish could, in principle, be analyzed as either D+IP or C+IP (though he analyzes them as Ds).

1. das nackt auf dem Rasen Liegen ist verboten
the nude on the lawn lie is prohibited
"it is prohibited to lie on the lawn nude"
2. no me gusta el cantar canciones españolas
not me pleases the to.sing songs Spanish

(1 and 2 from Felix 1988)

Such syncretisms across DPs and CPs could suggest a categorical alignment between them, especially with the structural similarities already addressed. The next few subsections will tackle this idea directly.

1.3.1 Parallelist Hypothesis- Strong Form

The strongest form of the this hypothesis argues that the DP and the CP are the same. This view is often (though not always) coupled with a cartographic⁴ (Cinque 1994) approach to syntactic structures. When these views are coupled together, all potential structural distinctions between DP and CP are gone. All of the functional categories and heads contained within the CP are contained within the DP and in the same order. The DP essentially is the CP.

Hiraiwa's approach outlined in the previous subsection can be seen as an example of this, though it does maintain a categorical distinction between DPs and CPs. Robust cartographic analyses also fit into this category. If the DP and CP are composed entirely of the same heads in the same order then the differences between D and C become irrelevant (and suspect if maintained).

1.3.2 Parallelist Hypothesis- Weak Form

There are also middle ground views which do not necessarily adopt the D=C categorical description, nor the Cartographic project wholesale. These approaches (seen in work like Roeper (2005) argue for particular parts of nominals being identical to their verbal counter-parts, but not necessarily for complete copying of the CP and DP.

In many ways, this dissertation (despite its title) fits in with the weaker forms of the Parallelist Hypothesis. At times throughout this dissertation, hierarchical organization will be assumed or argued to be the same across the nominal and verbal

⁴ outlined in the next section

domains. However, the strongest assumptions of the parallelist hypothesis are rejected on empirical and conceptual grounds.

The biggest “parallel” assumption of this dissertation is that the DP and the CP are the products of the same grammar. This, perhaps, does not sound that earth-shattering. It is expected. However, it is worth noting because much of this dissertation is devoted to showing that the apparent structural parallelism between the DP and the CP are a consequence of independent grammatical constraints and not of specified structural overlap.

1.3.3 The Anti-Parallelist Hypothesis

Logically, it is possible to produce a theory which has different “grammars” for the DP and the CP. I am unaware of any particular attempts to produce such a theory explicitly, but the issue should be addressed so that it can be quickly rejected.

Early generative grammar had a number of constraints that referenced some categories and not others. For instance, the NP-island Constraint (Ross 1967) made explicit reference to the nominal domain and only the nominal domain. However, these constraints were later subsumed under more general, category-independent constraints, such as Subjacency (Chomsky 1973) as the theory progressed. However, characterizing early generativist syntax as proposals for distinct grammars would be unfair. While there were specific constraints to specific categories the proposals were not meant to explain the “heart” of the grammar.

A modern theory that proposed such a category driven distinction would be hard pressed to justify it. Proposing that the DP and the CP are the products of different

grammars would violate every major assumption of the Minimalist Program. To make such a claim, the empirical evidence would have to be overwhelming.

This claim is not argued for in this work.

1.4 Cartography

Cartography (Cinque 1994) and parallelism are not logically connected—it is possible to have one without the other. There are cartographic approaches that don't discuss parallelism at all. Parallelism's roots, however, lie deep within the Cartographic framework. Indeed, much of the basis for the parallelist approach comes from Cinque's work on universals in adjective and adverb ordering (see Cinque 1999, 2002, 2007).

Like the parallelism, “cartography” covers a wide-range of (sometimes incompatible) views. All cartographic approaches share the assumption that functional heads are universally ordered—that is that languages do not differ in the relative order of functional heads. This form of the view has been largely adopted in modern syntax, even by “opponents” of cartography. Though, the connection between universal order and true “cartography” is not always there. For instance, virtually everyone believes in a universal order of CP over TP over VP, but this is not the outcome of cartographic work.

The strongest form of this approach holds that all languages (and each sentence of these languages) contain all functional heads. Each morpho-syntactic feature has its own syntactic head (see the *One Feature One Head Principle* (Cinque and Rizzi 2010) and discussion in van Craenenbroeck (2009) or the Tromsø Nanosyntax project (Starke 2011). Cinque and Rizzi (2010) estimate that there are 400+ functional heads which all are universally ordered.

Weaker forms of cartography have a reduced number of functional heads, but still assume universal order of these heads (see Rizzi 1996, Thráinsson 1996, Giorgi and Pianesi 1997, Bobaljik and Thráinsson 1998, Ritter and Wilstchko 2010) do not assume the *One Feature One Head Principle* and allow languages to differ in which features are associated with which head and each head can have a bundle of features rather than a single one. Many of these analyses also parameterize the heads themselves across languages. Taken together this means that functional heads are universally ordered, but that languages vary in the number and disposition of these heads.

The weaker proposal seems more tenable. It is plausible to assume that all languages do not utilize the same sets of features. Much of the work of typology has been aimed at showing universals in feature distributions across languages (see Greenberg's universals), which have led to theoretical organizational insights such as Harley and Ritter (2002):

3. Harley and Ritter (2002) Pronoun Feature Geometry

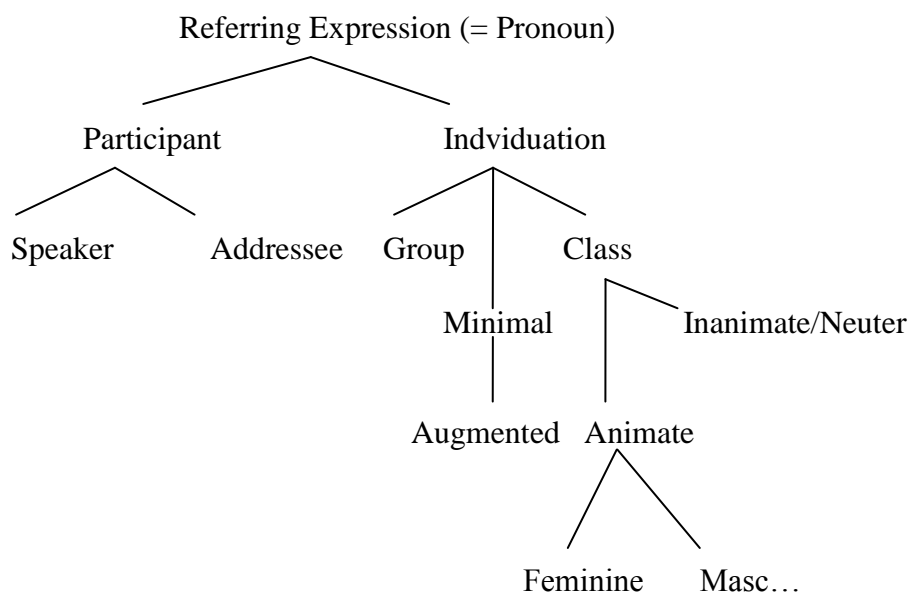

In the above geometry, for a language/speaker to have a feature it/he/she must also have all features that dominate it. This works well in explaining universals which show this pattern, however if we assume the strong form of cartography, then every feature would necessarily be present and be their own syntactic head. Why certain languages would be unable to utilize the “augmented” feature (distinguishing dual number) from the diagram above would be an unanswered question.

Many of the objections to cartography stem not from the universal order of functional heads (though the number of heads and the universality of those heads are a major sticking point) but from the way universality is derived by movement within the theory. The core cartographic works all assume an attraction-based approach to movement (see Chomsky 1995a, 2000, 2001). A higher projection has some featural requirement and probes below (within its c-command domain) to find a head which

contains a feature that can satisfy it. This attraction causes the lower head (plus anything it pied-pipes) to raise to an adjacent position.

This dissertation is aligned with the weakest forms of cartography. It assumes a universal order for functional projections, but does not assume that all languages utilize all functional heads. It does assume that the heads that are utilized are universally organized via selectional properties, for instance there is no language that projects *voice* below the verb.

4. Impossible Verbal Structure

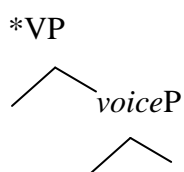

In this work, I assume the weakest form of cartography. However, there are some critical departures from even the weakest form that I make. Namely, I argue that some acategorical elements (roots, small clause particles) can be freely ordered with respect to each other. Such assumptions violate the basic tenets of cartography. Further, I assume that nominalization can target different projections within the verbal projections. While this may not be a violation per se, it could certainly be seen as a violation in spirit.

1.5 Form Identity and Labeling

The DM literature makes several compelling arguments against accidental homophony (see: Noyer 1992, Halle and Marantz 1993 and Halle 1997). I am very sympathetic to these arguments. An overabundance of accidentally homophonous forms

explodes the size of the lexicon. There are also conceptual reasons which seem to refute a homophonous lexical approach. Verbs like *kill* can vary greatly in their meaning based on their direct object, but the subject cannot show the same variation (see Marantz 1984 for detailed discussion).

5. John killed the audience.
6. John killed the bottle.
7. John killed his brother.
8. Mary killed.
9. The boy with the Arab Strap killed.

Despite this, it is still an open question whether or not all homophony within language can be eliminated. Even within DM, not all researchers pursue an analysis which eliminates **all** homophony. Work like Siddiqi (2010) does push for the elimination of all homophony, but most other research does not advocate for such a strong elimination of all homophony. It simply may not be possible. There is considerable evidence that languages avoid homophony, but there does not seem to be strong evidence that this aversion is absolute⁵.

Leaving aside null morphemes (which would pose a significant problem for homophony free approaches, but could be systematically discounted), there are other major problems for a completely ahomophonous grammar. Consider the English verbal tense and nominal number systems: in the verbal system the morpheme *-s* is an

⁵ A theory which attempts to avoid homophony absolutely would have to address the next to impossible task of unifying all null-morphological items into a single grammatical function/featural make-up.

agreement marker for 3rd person singular⁶ in the present tense, while in the nominal system it marks plural. In a strict homophonous grammar both uses of *-s* would have to be reduced to a single vocabulary item with a featural make-up that allow it to be inserted in the proper conditions, but no others. Such an analysis is certainly beyond my pay-grade.

Similarly, there is not broad overlap in morphology between verbal tense and nominal number. Only *-s* is form-identical across the two domains. If the two morpho-syntactic domains were linked at some deep level, would we not expect a great degree of overlap in forms? But, there is virtual no overlap.

Table 1-1 Syncretism in verbal and nominal suffixes

| Vocabulary Item | Verbal Tense? | Nominal Number? |
|-----------------|---------------|-----------------|
| -s | Yes | Yes |
| -ed | Yes | No |
| will | Yes | No |

The arguments about form-identity in verbal tense and nominal number may sound trivial to most readers. But consider the argument that form-identity is evidence for category-identity for D and C. Only *that*⁷ and *which* co-occur across both domains. Again, if there were some deep connection between the domains shouldn't we expect a great deal of overlap between forms? Again, the differences far outweigh the similarities.

⁶ I know of no attempts to reduce the English plural and the 3rd person present tense marker to a single morpheme. This example is presented to illustrate the reasonable limits on homophony analyses.

⁷ There is considerable evidence that *that* is not truly homophonous. While they are orthographically identical they are phonological dissimilar (see Radford 2004).

Table 1-2 Syncretism in determiners and complementizers

| Vocabulary Item | D-like Position? | C-like Position? |
|-----------------|------------------|------------------|
| That | Yes | Yes |
| Which | Yes | Yes |
| The | Yes | No |
| Some | Yes | No |
| Every | Yes | No |
| A(n) | Yes | No |
| One | Yes | No |
| Any | Yes | No |
| Those | Yes | No |
| This | Yes | No |
| Whether | No | Yes |
| If | No | Yes |

This does not necessarily mean that *that* could not be an instance of a single vocabulary item. All we know is that there is no *prima facie* reason for assuming that it must be. The discussion of assumption (2) will show it is possible to preserve the core of assumption (1) while not necessarily entailing that C and D are identical categorically.

If we reject assumption (2) then it is possible to maintain assumption (1) and still not assume that form identity necessitates strict identity across DP and CP. There are two distinct ways to implement a rejection of assumption (2). These ways would yield separate results. One way would be to reject the use of labels at all. Under this view there is no such thing as a D or C in any meaningful grammatical use. Such a view is compatible with versions of Bare Phrase Structure (see Fukui and Speas 1986, Speas 1990, Chomsky 1995b). This view would also be an *a priori* rejection of the strong form

parallelist hypothesis. The strong form deals with labeling of the phrases; if there are no labels the view cannot be correct⁸.

It is also possible that category labels are active in grammar, but not necessarily active in the selection of all lexical items. This view would allow for particular instances of form-identical items to be separate categories but still not accidentally homophonous.

Under either view the lexical content of *that* would be something like:

Label-free lexical entry for that
that: [distal] [discourse]⁹

Depending on the view of labels and phrase structure that we assume, a feature breakdown of *that* like the one given above could yield identical labels for DPs headed by *that* and CPs headed by *that*. However, even if we adopted such a view, this would not necessarily make the parallelist hypothesis true. DPs and CPs headed by other VIs would not be.

The issue of syncretism and labeling will be further addressed in chapter 3.

1.6 Outline of the Dissertation

This dissertation is broken down into six chapters including this one.

Chapter 2 discusses the distinction between derived nominals and nominal gerunds. It takes issue with Chomsky's (1970) discussion of nominal gerunds (there termed "mixed nominalization) and shows that the two constructions are fundamentally distinct and that nominal gerunds exhibit less syntactic complexity. I explain this

⁸ The term "label" has multiple uses in syntactic theory. It can refer to the structural make up of the sentence and whether or not nodes project themselves up, it can refer to category labeling or a combination of the two.

⁹ I do not wish to claim that this is the actual entry of or featural makeup for *that*. Rather, I am offering a **possible** entry for *that* which would capture both uses.

distinction by positing that the nominalizing heads associated with these constructions are structurally distinct.

Chapter 3 refines the analysis presented in chapter 2. It is concerned with two conceptual problems raised by the analysis given in 2. First, the arguments in chapter 1 critically depend on the preposition *of* having different properties in different syntactic contexts. In chapter 3, I motivate that distinction as best as possible. In this chapter, I also refine the distinction between the nominalizers in the previous chapter. In chapter 2, I argue that the necessary distinction is between where the nominalizer enters the derivation. In chapter 3, I roughly maintain that analysis but suggest that the presence or absence of a higher *kP* is the necessary distinction to tease apart the two constructions.

Chapter 4 is a departure of sorts from the main topic of the work. This chapter is largely concerned with the verbal domain—not nominalization. The chapter looks at some apparent counter-examples from Harley’s (2008) analysis of Latinate English verbs. Harley predicts that particles can never co-occur with Latinate verbs with compound or iambic stress—but such examples exist. In this chapter I show that such examples are not true counter-examples but rather are tied to idiosyncratic properties of the “particle” *away*. The chapter is necessary to lay the groundwork for chapter 5.

Chapter 5 addresses a major apparent problem for the analysis presented in chapters 2 and 3. Sichel (2010) noticed that derived nominals apparently disallow complex events while nominal gerunds allow them. If true, this would undermine the entire analysis. In this chapter, I reexamine Sichel’s generalization and show, based on the Latinate facts addressed in chapter 4, Sichel’s generalization is not true of complex

events, but particular morphological instantiations of those events. I analyze the morphological properties of the constructions and explain why complex events are generally morphological but not semantically incompatible with nominal gerunds.

Chapter 6 concludes the dissertation. It refocuses on some of the issues of the parallels between the verbal domain and the nominal domain based on the findings of the previous chapters. It also discusses future avenues for research based on the arguments presented in this work.

CHAPTER 2: NOMINALIZATION AND OBJECTS

2.1 Introduction

The goal of this chapter is to distinguish different types of nominalization. It accounts for the differences in argument structure in “mixed nominalizations” (Chomsky 1970) and true nominalization. True nominalization (nominalizations with nominalizing morphology such as *-(a)tion*) are shown to exhibit the same range of available argument structures as their verbal counterparts. Mixed nominalizations, nominals with *-ing* suffixation and *of* marking on objects (also known as nominal gerunds), are shown not to exhibit the full range of possible arguments.

This chapter considers these relationships and shows that object “arguments” of nominal gerunds do not exhibit any of the behaviors associated with object position of verbs. Using patterns of morphological/syntactic distribution, binding properties, polarity effects and lexical semantic variation, I show that nominal gerunds which have been considered to be near identical to derived nominals are in fact quite distinct from them. I show that apparent object arguments (understood objects of the root) of nominal gerunds fail every test of argumenthood and that the structural relations within these constructions are significantly different than those of derived nominals and verb phrases.

I conclude that the differences in argument structure are due to differences in the insertion points of the morphological heads associated with the different types of nominalization. Verbal gerunds are inserted above voice (as commonly assumed, e.g. in Baker 2005). The nominal gerund *-ing* occurs below where the voiceP/FP complex

would occur. While elements like *-(a)tion*, which form derived nominals, are a form of voice.

2.1.1 Organization of the Chapter

I begin with a discussion of a basic description of the nature/distribution as well as the terminological variants found throughout generative grammar used to describe the relevant phenomena. I then discuss the previous theoretic accounts of the distinction between true nominalization and nominal gerunds and the predictions of these accounts which I show are not borne out. I then show that there are critical differences in argument structure across these constructions and I provide a morpho-syntactic account of these differences. The chapter closes with a discussion of the nature of the subtle grammatical contrasts which are the basis of the analysis and provides several more tests to show that they are valid.

2.2 Gerunds

The status of gerunds has been a major issue within the status of nominals for decades (see: Lees 1961, Chomsky 1970, Abney 1987, Chierchia 1984, Baker 2005, among many others). The general consensus is that there are (at least) two¹⁰ distinct type

¹⁰ Chierchia (1984/1988) following (Roper and Wasow 1972 and Horn 1975) divides gerunds into three distinct groups: ACC-ing constructions (V-gerunds), POSS-ing constructions (NP-Gerunds) and CN-Gerunds (common noun). All data below from Chierchia (1998).

- 1) Acc-ing constructions:
 - i) John hates someone being killed.
 - ii) John disapproves of him helping Mary
 - iii) Mary didn't have to pay, her husband owning the place.
- 2) POSS-ing constructions
 - i) We deprecate John's always being late.
 - ii) We attribute great importance to John's being elected.
 - iii) John's quitting that job surprised me.
- 3) CN-gerunds
 - i) The killing of prisoner of war is a crime.

of gerunds, one which is essentially a verb phrase and the other which is more like a noun phrase. The verbal gerund is the least controversial and typically analyzed as a full *vP* with DP-structure added on top. The status of the nominal gerund is less understood. Chomsky (1970) argued that the nominal gerund is a “mixed” class containing both elements of the verbal system and of true nominalization. Harley and Noyer (1998) argued that the nominal gerund is identical to other forms of nominalization. However, a closer examination of the data shows that both of these claims are incorrect. Nominal gerunds are not identical to other forms of nominalization, but they are also the *least* like the verbal system contra Chomsky’s (1970) proposal.

2.2.1 An Aside on Terminology

As illustrated in footnote 10, there is no agreed upon terminology for the different classes of gerunds. Chomsky (1970) uses the terms “nominal gerunds” and “mixed nominalization” to describe the two classes under discussion here. Chierchia (1984) develops his own terminology Siddiqi (2010), who attempts to provide a DM-account of *-ing*’s distribution, provides yet another set of terms. Abney (1987) and Baker (2005) are the most faithful to the terms used in the groundbreaking scholarship in this area (Lees 1961, Roeper and Wasow 1972 and Horn 1975) but the terms are the most opaque. (see the table in 2-1)

-
- ii) Loud singing disturbs me.
 - iii) It took many readings for me to understand that paper.

The Poss-ing constructions (NP-Gerunds) are equivalent to what I have termed true gerunds here. CN-gerunds are equivalent to mixed nominalization (Chomsky 1970) which I have also termed nominal gerunds for compositional interpretation of the terminology. The status of Chierchia’s V-gerunds as gerunds in any meaningful way is an artifact of the analysis that Chierchia was pursuing which treated control and ECM constructions as VPs not Clauses (S, in the terminology of the framework). My treatment of gerunds will not include Acc-ing constructions.

Given the lack of a standard set of terms to describe the phenomena, I will implement a single terminological convention. The terminology in this work most closely follows Parson (1990). While avoiding confusion should be the first priority, it is impossible given the number of terms out there. Instead, I will try to utilize terms most consistent with my assumptions and conclusions. In general, I will avoid the use of Chomsky's term "nominal gerund" due to its similarity to my term "nominal gerunds" and Chierchia's "common noun-gerund" both of which refer to Chomsky's "mixed nominalization".

The terminology is summed up in the following table.

Table 2-1 Terminology associated with nominalization

| | “Classic” terms | Chomsky (1970) | Chierchia (1984) | Parsons (1990) | Siddiqi (2010) | This work |
|--|------------------------|----------------------|------------------|-----------------|-----------------|------------------------------|
| Accusative subjects, VPs in argument position | ACC-ing Constructions | N/A | Verbal gerunds | | Verbal Gerunds | N/A |
| Gerunds modified by adverbs, subject marked by - ‘s, direct case marking | POSS-ing Constructions | Nominal gerunds | NP-Gerunds | Verbal Gerunds | Hybrid Gerunds | True gerunds/ Verbal Gerunds |
| Gerunds modified by adjectives, no direct case marking | | Mixed Nominalization | CN-gerunds | Nominal Gerunds | Nominal Gerunds | Nominal gerunds |

2.2.2 True Gerunds

The most straightforward class of gerunds is the true gerund. These are gerunds that behave virtually identically to Verb Phrases. Lees’ (1961) foundational work on the subject showed that all verb phrases can be made into gerunds of this type—a level of productivity unheard of in other corners of nominalization. These gerunds also exhibit identical modificational properties as Verb Phrase: they must be modified by adverbs not adjectives; they may have auxiliaries; they directly assign Case to their object arguments (Lees 1961, Chomsky 1970, Abney 1987, Baker 2005, among many others). These properties can be seen in 10 and 11 below. In 10, modification is unambiguously

adverbial and the object is directly case marked (i.e. there is no *of*). In 11, an auxiliary is present in the gerund and case marking is again direct.

10. John's quick*(ly) riding his bike in the rain made him wet.

11. John's having eaten fish for the first time made him ill.

This class also behaves in ways that separate them from other DP arguments.

Unlike common nouns, derived nominals or (as we shall soon see) nominal gerunds, in verbal gerunds subject arguments are obligatory and determiner-like elements are blocked (Abney 1987, Baker 2005) seen in the ungrammaticality of 13.

12. John's writing a letter to congress demonstrated that he was a model citizen.

13. *The/*A writing a letter to congress shows one to be a model citizen.

The subject element can be null, however:

14. PRO_{ARB} writing a letter to congress shows one to be a model citizen.¹¹

The most widely accepted analysis of these constructions is some variation on Abney's (1987) proposal, which has a GER (gerund) head (in Abney's analysis it was the actual noun, in the noun phrase) which is structurally higher than a verb phrase. This analysis captures the cobbled-together feel of verbal gerunds which are distributionally noun phrases, but structurally verb phrases. Baker (2005) offers a more modern treatment of this analysis. In Baker's analysis GER is a functional head which is present in the structure instead of INFL or T.

¹¹ The classification of examples 13 and 14 is not universally accepted. The issue is whether PRO should be treated as Accusative Case marked, Genitive Case marked or neither. At this point, distinguishing these constructions is not relevant so they will be left aside.

2.2.3 Nominal Gerunds

Nominal gerunds hold a peculiar place within the theory, and have not been given a treatment of their own. Nominal gerunds are marked with *-ing* and mark their subjects with *-s* like verbal gerunds, but take adjectives instead of adverbs, cannot have auxiliaries and cannot directly assign Case to their objects, marking them with *of* instead. Alexiadou (2001) also suggests that nominal gerunds are not productive; a fact which will be disputed towards the end of this chapter.

15. John's quick(*ly) riding of his bike in the rain made him wet.

16. *John's having eaten of fish for the first time made him ill.

(contrast with: 16b. John's eating of fish...)

Chomsky (1970) first introduced the notion that these exhibited “mixed” properties because they introduced their object arguments with *of* but were marked in the *-ing* of the verbal gerunds. Harley and Noyer (1998) disputed the “mixed” status of these constructions. They argued that the *-ing* found in nominal gerunds was an elsewhere case for derived nominal morphology and that this accounts for a difference in verb particle alternations across gerund-types. Verbal gerunds allow the same positional variation of particles as verb phrases, while nominal gerunds do not. Harley and Noyer use that fact to argue that there is nothing “mixed” about these constructions. The relevant contrasts is in the possible position of the verb particle *up* between the verb phrase/verbal gerunds (examples 17-20) and the nominal gerunds (examples 23 and 24).

17. Chris rapidly wrote the paper up

18. Chris rapidly wrote up the paper.

19. Chris's rapidly writing up the paper...

20. Chris's rapidly writing the paper up...

The same structural analysis can be given to both structures, such as the following (adapted from Harley & Noyer 1998, and Ramchand & Svenonius 2002). In these structures, the particle optionally incorporates into the verb before the verb head moves. When particle-incorporation occurs, the particle surfaces adjacent to the verb. When it does not, the particle surfaces in a verb phrase final position because the object A-moves around it.

21. "Stranded" Verb Particle

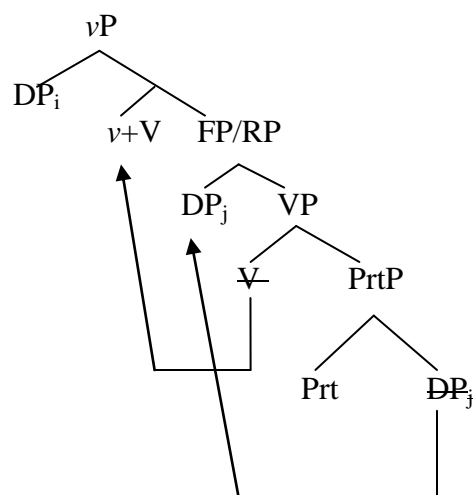

22. “Verb-Particle-Object Construction

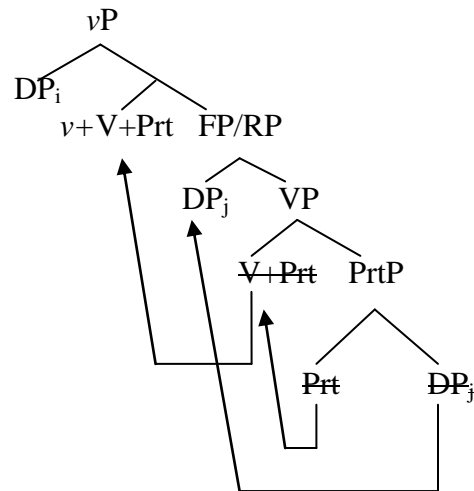

However, the structures in 21 and 22 are incompatible with the mixed nominalizations facts. There is no variation in the placement of verbal particles in nominal gerunds. Particles most always occur adjacent to the root, adapting the same structures would predict that examples like 24 (below) should be grammatical.

23. Chris's rapid writing up of the paper...

24. *Chris's rapid writing of the paper up...

Harley and Noyer conclude from this that the structure of nominal gerunds must be something like 25 below.

25. Structure of Nominal Gerunds

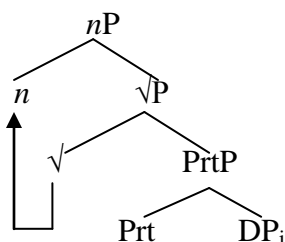

In 25 there is no position for the DP to raise into; *nP* does not license the necessary functional structure (FP/RP in 21 and 22); the reasons behind this failure will become more apparent in later chapters. Because of this the particle is obligatorily next to the root even after movement¹². Thus, particle incorporation is a vacuous operation in such a structure; regardless of whether or not the particle incorporates the particle will surface in verb-adjacent.

Harley and Noyer (1998) go further analyzing nominal gerunds as a sub-class of derived nominals. They predicted that forms of the type [N+ing of] should always be ungrammatical when [N+tion of] can be inserted. Within Distributed Morphology (Halle & Marantz 1993, Harley and Noyer 1999) morphological elements are inserted following the completion of the relevant syntactic derivation (e.g. a phase). Morphological elements compete for exponence and whichever element best fits without having “too much” or information associated with the morpheme that is not present in the syntactic environment is inserted.

If this second part of Harley and Noyer (1998) is correct then the following consequences should follow:

¹² It is impossible to tell whether or not the particle incorporates as in 22 or remains free as in 21. Both would yield identical results.

- I. [N+ing of] constructions should always be ungrammatical when [N+tion of] is available
- II. Nominal gerunds and derived nominals should exhibit identical structures.

Neither of these consequences is correct.

Consequence I is questioned in Harley and Noyer (1998) itself, as seen in the examples found in 26 below.

| | | | |
|-----|---------|----------------|----------------|
| 26. | admire | admiration of | ?admiring of |
| | destroy | destruction of | ?destroying of |
| | inspect | inspection of | ?inspecting of |
| | mix | mixture of | mixing of |
| | move | movement of | moving of |
| | marry | marriage of | marrying of |

In [17 above] we provide further examples of the blocking effect (or lack thereof) correlated with the existence of a specialized meaning for the specialized nominalizing affix. We predict, of course, that a mixed nominalization should be acceptable only to the extent that a morphologically specialized nominalization has a specialized meaning.

(Harley and Noyer 1998)

Harley and Noyer paint themselves into corner. If their approach is correct then the blocking effects should be robust. The fact there is no strong blocking effect in any of the example cases suggests that at least some part of the approach was incorrect.

However, if *-(a)tion* and the nominal gerund marking *-ing* are actually realized in different environments the apparent free variation between the two options would not pose a problem for DM since blocking would no longer be relevant.

A couple of facts are overlooked by Harley and Noyer (1998) with respect to differing behaviors between nominal gerunds that suggest that these are structured differently: As we will see in the next section, object arguments cannot bind each other in nominal gerunds, whereas they can in derived nominals. Derived nominals can also be

modified temporally while nominal gerunds cannot. Following Grimshaw (1990) these facts are related. Grimshaw (1990) argues that the ability to take temporal modification is a necessary prerequisite for argument taking in nominal.

2.3 Binding Theory and the Derivation of Nominals

Barss and Lasnik (1986), in their classic paper on ditransitives note that objects asymmetrically c-command each other (27-30):

John showed Mary herself.

27. *John showed herself Mary.

28. John showed Mary to herself

29. *John showed herself to Mary

This insight leads Larson (1988) to claim that there is a split structure within the VP (a modified version of which is seen in 22), which allows one object to asymmetrically c-command the other -- a necessary condition for the binding facts to be explained. The adoption of this structure also solves a puzzle of how have two object arguments within the constraints of X'-Theory (Chomsky 1970, Jackendoff 1973, 1977).

30. Split VP-Structure

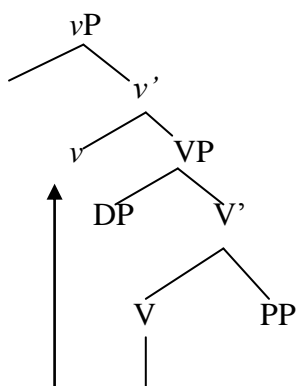

Since its proposal, the split VP- analysis has been nearly universally adopted, with some modifications (see Kratzer 1996). The analysis has been extended to other projections. Many modern analyses of nominal construction contain an nP^{13} projection that is analogous to Kratzer's VoiceP (which in turn has been identified as vP and is also equivalent to Larson's outer VP shell). But ditransitive nominalizations do not behave as a uniform group. Verbal gerunds behave exactly like verb phrase (32-35), as expected.

- 31. John's showing Mary herself.
- 32. *John's showing herself Mary.
- 33. John's showing Mary to herself
- 34. *John's showing herself to Mary

By contrast, the mixed nominalizations do not show the same binding relationships (36-39). Neither object "argument" of a ditransitive nominal gerund can bind the other.

- 35. %¹⁴John's showing of Mary to herself...

¹³ This is again an area where naming conventions can derail discussion. Projections like nP or vP (generalized to xP) can serve two different functions in the literature. Sometimes they are meant to be roughly equivalent to Kratzer's (1996) VoiceP. These projections introduce external arguments and have other properties associated with voice. Within the DM literature (Marantz 1997, 200#), xP can simply be a head that introduces category to the root without other properties of Voice.

Radford's nP is equivalent to Voice. The nP that is used later in this chapter is just a category assigner.

¹⁴ There is some variation in the acceptability of examples like 35. Some speakers appear to show a strong dispreference for nominal gerunds generally; this is especially true of gerunds. In general, when a derived nominal is possible, it appears to be preferred. However, nominal gerund forms of verbs which can be derived nominals are found frequently enough to suggest that these are not "errors". They can also be found in media sources dating from the late 1800s until today. I have yet to find a single source that uses a ditransitive with co-referring objects (as I would expect to not find).

To take an illustrative example: the bigram "introducing of" appears roughly 54,000 times in a Google book search. In contrast, "introduction of" appears over 34 million times.

36. *John's showing of herself to Mary...

37. John's showing Mary to herself...

We can contrast the unacceptability of anaphors with the acceptability of general apparent ditransitives.

38. John's showing of Mary to Bill (bothered Mary's husband)

This restriction is not due to the presence of a preposition. Binding out of *of* prepositional phrases is possible in other forms of nominalization. Derived nominals with *-tion* have identical surface forms with respect to the position of the object "arguments", and *-tion* nominals introduce their arguments with *of* as well. But as seen in 32 and 33, *-tion* nominals allow *of* arguments to bind, while nominal gerund arguments do not.

39. John introduced the boys to each other.

40. John's introduction of the boys to each other...

41. *John's introducing of the boys to each other....

42. John's introducing of the boys to Mary...

Since binding isn't possible with nominal gerunds¹⁵, but is possible with other forms of nominalization, an explanation is required. There are no apparent (surface)

That said, I believe it would be a mistake to read too much into the discrepancy of use of these construction—but the non-isolated appearance of "introducing of" does suggest that it is a valid form of nominalization.

¹⁵ It may well be the case that there is variation within English speaking populations about the permissibility of binding in these examples. There are a number of potentially complicating factors concerning this construction. For speakers for which the constructions are marginal to begin with, judgments on the acceptability of anaphor-binding will already be compromised. Further, though somewhat speculative, there is a ready repair strategy for these examples: deletion of *of*; anaphor-binding is unquestionably acceptable in verbal gerunds.

restrictions on the number of arguments, based on the type of nominalization. Nominal gerunds appear to show ditransitives- like argument structure when appropriate.

43. John's giving of a car to Mary...

44. John's showing of Mary to Jill...

The lack of binding in example 32 doesn't appear to have an easy explanation in the argument structure. There are no apparent restrictions on the number of arguments to distinguish the two forms of nominalization. The explanation must therefore be structural. Identical structure should yield identical binding relations.

One possible solution is to treat the "arguments" of mixed nominals as adjuncts. Adjuncts are in different positions than arguments so such an analysis may yield results. This is the approach that will be taken.

This solution is not without pitfalls. Under the classic constraints on binding no distinction is made between arguments and adjuncts. Binding is defined in terms of c-command alone, without reference to argument status.

Principle A: an anaphor must be bound (c-commanded by an antecedent) in its binding domain.

Principle B: a pronoun must be free (not c-commanded by an antecedent) in its binding domain.

This may be an area where experimental support would be greatly beneficial. However, the feasibility of such a study is undermined by the constructions marginality for some and the relative paucity of available test items (ditransitive verbs which can take animates in both object positions). While possible, it would take a more creative mind than mine to design.

Regardless, even if the binding facts are not fully accepted the uncontroversial facts of negative polarity and verb-object idiomaticity still suggest that the analysis presented in this work has legs.

Neither principle states that the antecedent must be in an argument position. So binding should be possible whenever a c-command relationship is present, ruling out structures like 36 for nominal gerunds. 36 is the structure of a ν P, with the shaded area representing the region c-commanded by “the boys”.

45. . . .introduce the boys to each other. . . .

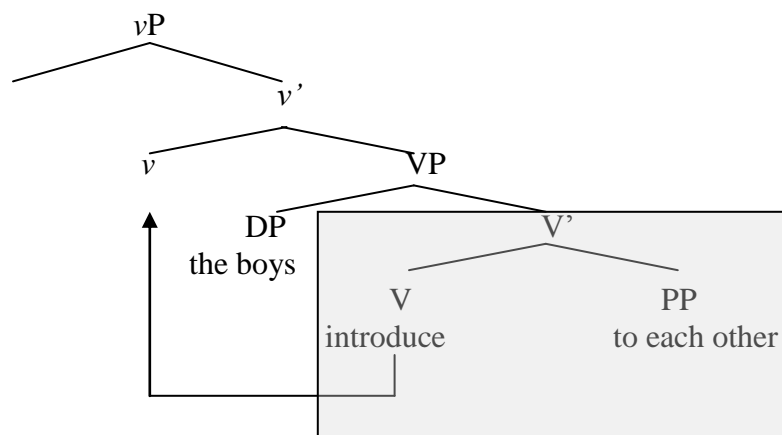

Even though a structure like 36 can be easily ruled out, an alternative adjunct structure will still yield an apparent incorrect result. The structure like that found in 38 would correctly predict that *the boys* cannot bind *each other* because it does not c-command it. At first blush this seems like a good result. However, recall that neither argument can bind the other one. A structure like 38 would incorrectly predict that 37 is grammatical, because *the boys* c-commands *each other* and should be able to bind it (see the structure in 39).

37. *John's introducing of each other_i to the boys_i

46. . . .introducing of the boys to each other....¹⁶

47. . . .introducing of each other to the boys

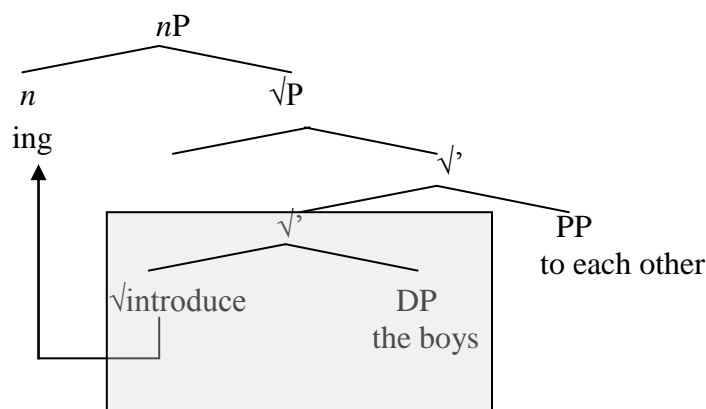

The lack of binding within nominal gerunds leaves us with something of a puzzle.

They clearly cannot have the same structure as the verbal system because that would predict that the binding relationships should be identical between the two classes. The proposed adjunct analysis has a similar problem; it seems to predict that the binding relationships should be the opposite of those in the verbal system, but that there should still be binding. This is also not correct.

Work on Binding Theory rarely makes direct reference to a distinction between argument and adjuncts, but it does subtly slip into much of the work on the subject. Much of the early work on binding theory, focused on where different principles applied (DS, SS or LF). Application at DS can essentially target only arguments, because DS was the level of theta-assignment. Lebeaux's (2009) (along with others like Hornstein 2000)

¹⁶ The structures given in 46 and 47 assume some form of Bare Phrase Structure (Speas 1990, Chomsky 1995). However, this assumption is irrelevant to the discussion. The same c-command relationships would exist if we assumed a classic X' structure (Chomsky 1970 Jackendoff 1973).

continuation of this work takes this a step further. He proposes separate base structures for theta-assignment and functional structure related to case which are then fused later in the derivation.

48. . Lebeaux's (2009) Model

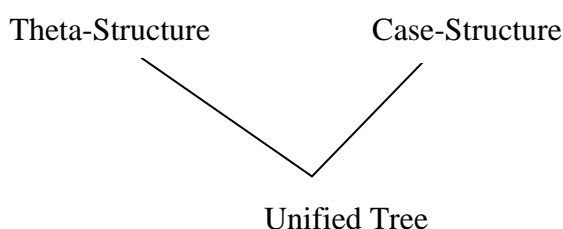

While a full run-through of Lebeaux's (2009) proposal is beyond the scope of this chapter it is important to note that he *does not* associate Principle A with theta-assignment. His argument is that Principles B and C hold at all levels of a derivation, while Principle A holds only at LF.

Some scholars have directly related the connectedness of Theta-assignment and binding. Williams (1987) argued that binding was not a property of NPs but a property of the Theta Roles associated with them. His analysis was based on the behavior of implicit arguments (essentially PRO and pro) with respect to the Binding Conditions. This account predates the introduction of PRO and pro as grammatical objects, but Williams' insight may still be relevant. If the analysis of arguments of nominal gerunds is correct, then an approach like Williams' would generate the correct result. Binding would be blocked; however, this would not be due to the lack of c-command but because the non-theta marked elements do not participate in binding.

However, the negative polarity facts to be discussed soon show that a theta-account is in fact not sufficient to explain the argument-structure facts of nominal gerunds¹⁷.

2.4 “Object Arguments” of Nominal Gerunds as Adjuncts: C-Command

Since Barss and Lasnik (1986), it has been known that direct and indirect objects exhibit properties of asymmetric c-command (which argument is the binder varies by construction). The objects of ditransitive predicates in nominal gerunds exhibit no evidence of a c-command relationship: Objects of ditransitive nominal gerunds cannot bind each other; nor do they allow Negative Polarity Items.

Examples 49 and 50 show both of these restrictions. In 30, the reflexive anaphor *each other* is not permitted because there is not an appropriate c-commanding binder within its domain. This is surprising because *the boys* is an appropriate antecedent in other analogous constructions discussed below. Similarly, the NPI *anyone* in example 31 is not licensed because it is not c-commanded by a negative item despite the presence of *no boy*.

49. *John’s introducing of the boys]_i to [each other]_i.

50. *John’s introducing of no boy to anyone.

In contrast to 49 and 50, verb phrases, verbal gerunds and derived nominalization all show c-command relations between their objects.

51. John introduced [the boys]_i to [each other]_i.

¹⁷ Though, such an analysis could potentially explain why binding would be allowed and negative polarity and verb-object idiosyncrasies disallowed should the binding judgments be shown to be experimentally invalid (though, I believe the judgments to be robust).

- 52. John introduced no boy to anyone.
- 53. John's introducing [the boys]_i to [each other]_i.
- 54. John's introducing no boy to anyone
- 55. John's introduction of the boys to each other.
- 56. John's introduction of no boy to anyone.

On first pass it appears that the presence of the preposition *of* could be preventing the binding relationship in 49 and 50. An argument introduced by *of* should not c-command the lower argument. Such an analysis is belied by the fact that derived nominals (55 and 56) also require the presence of the preposition *of* but still exhibit c-command relationships. That shows that the preposition itself does not prevent the higher argument from c-commanding the lower one.

2.5 “Object Arguments” of Nominal Gerunds as Adjuncts: Semantic Interpretations

Verbs and their objects have a very close relationship such that the meaning of one can greatly affect the meaning of the other. Marantz (1984) shows that the Verb-Object relationship can create vastly different interpretations of the same verb. Work on resultatives (Simpson 1983, Carrier and Randall (1992), Levin and Rappaport (1996), others) has shown that only an object can be the affected party (discussed in section 2.5).

Marantz (1984, onward) shows that the close relationship between a verb and its object allows for idiosyncratic meanings that are not found (at least as robustly, see Kratzer 1996) with subjects or adjuncts.

- 57. John killed a man.
- 58. John killed the conversation.
- 59. John killed the bottle.

60. John killed the audience.

In each of the above examples the interpretation of *kill* is dependent on the object argument. Adjuncts do not show the same idiosyncrasies.

61. John killed at 3pm.

62. John killed with a hatchet.

63. John killed while thinking about the Green Isles.

Adjuncts can tease apart ambiguities with respect to *kill* but they cannot extend the meaning like objects can. Examples 64, 63 and 65 are at least partially ambiguous between a literal meaning (cause the death of) meaning and a metaphorical one.

64. John killed the audience

- a. John is a mass-murderer.
- b. John is a talented comedian.

This same ambiguity is found in verbal gerunds.

65. John's killing the audience lead to his getting a sitcom.

- a. John is a mass-murderer, and the American public longs for that.
- b. John is a talented comedian, and should therefore be on TV.

This is unsurprising given the Abney/Baker-style analysis advocated for in this dissertation. The relevant sections of structure are identical between verb phrases and verbal gerunds, so any meaning facts attributable to the structure should be identical.

Nominal gerunds do not share this ambiguity. This is perhaps not a major surprise, but it is a peculiar fact. Marantz's (1984) analysis of object-verb idiosyncrasies did not reference any higher structure. For Marantz the fact that the root directly assigns a theta role to the object is the only necessary condition for deriving the idiosyncratic meanings.

66. John's killing of the audience lead to his getting a sitcom.
- a. John is a mass-murderer, and the American public longs for that.
 - b. #John is a talented comedian, and should therefore be on TV.

The fact that nominal gerunds lack any idiosyncratic meanings strongly suggests that object "arguments" are not assigned a theta role by the root. This fact coupled with the binding facts discussed previously shows that these "arguments" behave more like adjuncts than true arguments.

This is even more striking when these "arguments" are coupled with adjuncts that would typically tease apart the two idiosyncratic meanings.

67. John killed the audience with impeccable comic timing.
- a. The audience was greatly amused by John.
 - b. The audience was murdered by John in a farcical manner.
(much harder to get)

68. John killed the audience with a hatchet.
- a. #^{??} John is a prop comedian, and amused the audience.
 - b. John murdered the audience with a hatchet.

69. John's killing of the audience with impeccable comic timing...
- a. #The audience was greatly amused by John.
 - b. The audience was murdered by John in a farcical manner.
(only available reading)

In nominal gerunds the non-death reading is impossible even with the presence of an adjunct that would normally skew the reading towards the metaphorical/idiosyncratic reading. This evidence supports Marantz's argument that the semantic (theta) relationship between the verb and the object are what drive the idiosyncratic meanings. If contextual clues were the primary driving force behind idiosyncratic interpretations then 69a should be the primary interpretation of 69. These facts also argue against Bressan (1982) and Grimshaw (1990)'s claim that V-O meaning idiosyncrasies can be reduced to processing

effects. The changes in surface order appear insignificant, but because adjuncts do not share the same close relationship with verbs they cannot open up the other interpretations.

2.6 “Object Arguments” of Nominal Gerunds as Adjuncts: Resultatives

As noted in Simpson (1983), Carrier and Randall (1992), Levin and Rappaport (1996) and many others, only direct objects allow resultative modification (even if the direct object has subsequently moved as in unaccusatives).

70. Terry wiped the table clean

71. *Terry wiped the table exhausted.

(70-71 adapted from Levin and Rappaport (1996))

72. The gardener watered the flowers flat.

73. The joggers ran their Nikes threadbare.

(72-73 from Carrier and Randall (1992))

Resultative constructions are impossible in nominal gerunds. This fact falls out of the analysis of understood objects of nominal gerunds as adjuncts. There is no direct object for the result to apply to, so the constructions are uninterpretable. In examples 74-76, the understood object is not a true object. Because results can only be interpreted as happening to a syntactic direct object, the appropriate interpretation is unavailable.

74. *Terry’s wiping of the table clean...

75. Terry’s wiping the table clean...

76. *The gardener’s watering of the flowers flat...

77. The gardener watering the flowers flat....

In the DM literature these constructions like those in 70-77 are treated as small clause constructions with the insertion of the verb directly into the voice-head (see Harley 2008, among many others).

78. John hammered the metal flat.

79. Structure of 78

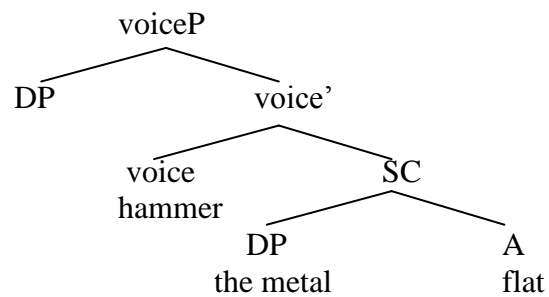

(Harley 2008)

Such analyses are supported by the claim that the adjectival component of the small clause can be raised into the voice-head when there is no verb.

80. John flattened the metal

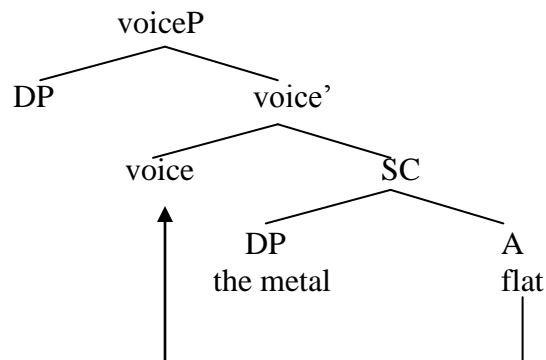
81. Structure of 80¹⁸

(Harley 2008)

The lack of such constructions in nominal gerunds again falls out naturally from the analysis given so far. Nominal gerunds lack Voice (or event P from the earlier discussion), so these constructions should be disallowed.

2.7 Derived Nominals

Left out of the discussion so far is the behavior of derived nominals. There is good reason for this; they seem not to participate in any of these constructions. This might seem like a major flaw for the analysis given in the earlier part of the chapter. The differences between derived nominals and nominal gerunds drove the analysis, but if they, like nominal gerunds, disallow resultatives and motion verbs that might call the entire analysis into question.

82. John's destruction of the audience
(only one possible interpretation)

83. *John's destruction of the city clear....

¹⁸ There are alternatives to this analysis such as predicate composition (Wechsler 2005).

What differentiates derived nominals from nominal gerunds is the fact that examples like 82 and 83 are also not permitted in verbal constructions.

84. John destroyed the audience.

85. John destroyed the city.

86. *John destroyed the city clear.

Again, 84 and 85 have only one possible interpretation, which is unaffected by the object argument. 86 is ungrammatical. This pattern holds throughout the derived nominal paradigm. It is then not a fact about derived nominals but about the roots from which these nominals derive (contrast that with nominal gerunds where it is only in the nominal form that such structures are disallowed).

This answer is not satisfying. What is it about the roots of derived nominals that disallow these constructions? And what can this tell us about the structure of derived nominals versus the structure of nominal gerunds?

Harley (2008) notes that certain verbs cannot participate in resultative or particle constructions. Harley also notes that all of these verbs are of Latinate origins and (at least) bisyllabic.

87. Verb particle constructions (from Harley 2008)

| Anglo-Saxon | Latinate |
|--------------------|----------------------------------|
| write it up | *compose it up/*arrange it up |
| eat it up | *consume it up |
| finish it up | *complete it up |
| throw it out | *discard it out |
| lie down | *recline it down |
| hand it out | *distribute it out |
| show it off | *exhibit it off / *reveal it off |
| fire it up | *ignite it up |
| slice it off | *incise it off |
| tidy it up | *arrange it up |
| hide it away | *conceal it away |
| cut it apart | *dissect it apart |
| figure it out | *calculate it out |
| move it over | *displace it over |
| go away | *depart away |
| clear it up | *clarify it up |
| cast it off | *release it off |
| dig it up | *excavate it up |
| swell up | *expand up |
| trade it in | *exchange it in |

88. Resultative Constructions (from Harley 2008)

| Anglo-Saxon | Latinate |
|----------------------|-----------------------------|
| cut it apart | *divide it apart |
| fill it full | *inflate it full |
| walk yourself tired | *perambulate yourself tired |
| work yourself ragged | *decide yourself ragged |
| squeeze it empty | *compress it empty |
| stab it dead | *impale it dead |
| train yourself fit | *condition yourself fit |
| freeze solid | *congeal solid |
| dance yourself pink | *exert yourself pink |
| eat yourself sick | *devour yourself sick |
| scrape it raw | *abrade it raw |
| break it short | *divide it short |
| grow big | *expand big |
| burn black | *combust black |

To explain the facts in 87 and 88 Harley argues that Latinate verbs are bipartite (actually tripartite when her 2008 analysis is coupled with her 2005 analysis which separates the verbalizing head from the external-argument-introducing head). This analysis is discussed in much greater detail in chapters 4 and 5.

It happens that a great number of derived nominals are Latinates, so the lack of resultatives appears to be non-problematic in many cases. It derives from the same solution as in the verbal system. The general failure of results and particles in derived nominals is explained in chapter 5.

89. Derived Nominals

| Anglo-Saxon | Latinate |
|--------------------|-----------------------|
| *writation | composition |
| *eation | consumption |
| *finishation | completion |
| *handation | distribution |
| *showation | exhibition/revelation |
| *fireation | ignition |

The relevant point from this discussion is not that *-(a)tion* can only target words of Latinate origin, but that *-(a)tion* can only target verbs which are bipartite in structure (of which Latinate verbs are). This is illustrated by the behavior of derived verbs which are also necessarily bipartite in structure.

90. Fridtjof Nansen's winterization of the equipment made the expedition possible.

91. *Fridtjof Nansen's winteration in Tucson was an annual treat.

In contrast to *-(a)tion*, the nominalizing *-ing* can target both bipartite and single-head verbs.

92. Fridtjof Nansen's winterizing of the equipment made the expedition possible.

93. Fridtjof Nansen's wintering in Tucson was an annual treat.¹⁹

Descriptively, it appears that derived nominals need verbal structure that is (at least) bipartite. Nominal gerunds seem not to care about the amount of verbal structure in any way. Derived nominals also maintain the same argument structure as their verbal counterparts whereas nominal gerunds exhibit quirky behavior from apparent objects—not expected from true arguments. The simplest account is one that can account for both of these facts, which is most likely structural.

2.8 The Location of Derivation

The main question now is where these nominalizing derivational heads occur in the structure of the verb/root phrase. Both heads essentially carry out the same operation; they convert a verbal projection into a nominal one, but with massively different results.

Derived nominals require verbal structure that is at least bipartite. Nominal gerunds *can* apply to bipartite verbal structure, but do not require it. At first blush, this prevents an analysis of nominal gerunds based solely on the amount of verbal structure. If that were the case, then we would predict that when –ing is attached to a bipartite verb the full range of argument structure would be allowed. That is not what is seen. This

¹⁹ Examples like this are on the surface ambiguous as to whether they are nominal or verbal gerunds because they are intransitive and the relevant distinction between the two is in the behavior of the objects when a subject is present. However, the subjects of nominal gerunds are optional while they are required for verbal gerunds.

- I. The introducing of the boys to Mary... (nominal gerund)
- II. *The introducing the boys to Mary... (verbal gerund)

Examples like “wintering” clearly pattern with the nominal gerunds because the subject is optional.

- III. John's wintering in Tucson was canceled for financial reasons.
- IV. The wintering in Tucson was canceled for financial reasons.

suggests that the point of insertion must be higher for the derived nominals. Harley (2006) puts *-(a)tion* just above vP, excluding FP and voiceP²⁰.

94. Adapted Harley (2006) Derived Nominal Structure

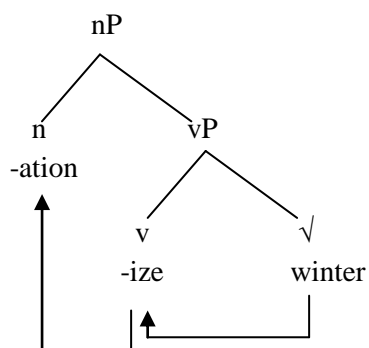

The problem with this analysis is that there is no way to structurally distinguish derived nominals from nominal gerunds when a bipartite verb is involved (cf. 95).

95. Structure of nominal gerunds

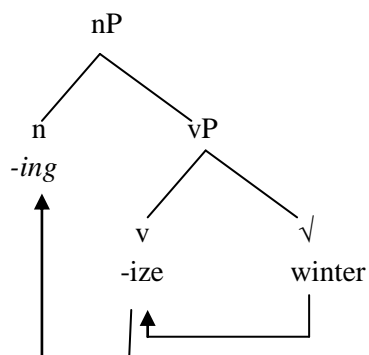

The nominalizing *-ing* cannot occur any lower in the structure because it is possible to have an overt verbalizer (like *-ize* in 95) in a nominal gerund ; But, if it occurs in the same position as *-(a)tion* then the problems outlined above emerge: they

²⁰ Harley (2006) argues that the verbalizing head (little *v*) and the voice head are critically distinct. The analysis presented here assumes that analysis.

should behave identically. Because *-ing* cannot occur any lower, *-(a)tion* must therefore occur at a higher structural position.

The issues with having *-(a)tion* higher are discussed in Harley (2006). In her discussion about why voice and *v* must be distinct categories, she shows why *-ation* cannot occur higher than voiceP. Under the assumption that voiceP licenses the object case in SPEC-FP, we would expect object of derived nominals to have accusative case (as in example 96 and the derivation in 97).

96. *The Romans' destruction the city...

97. Illicit derived nominal structure

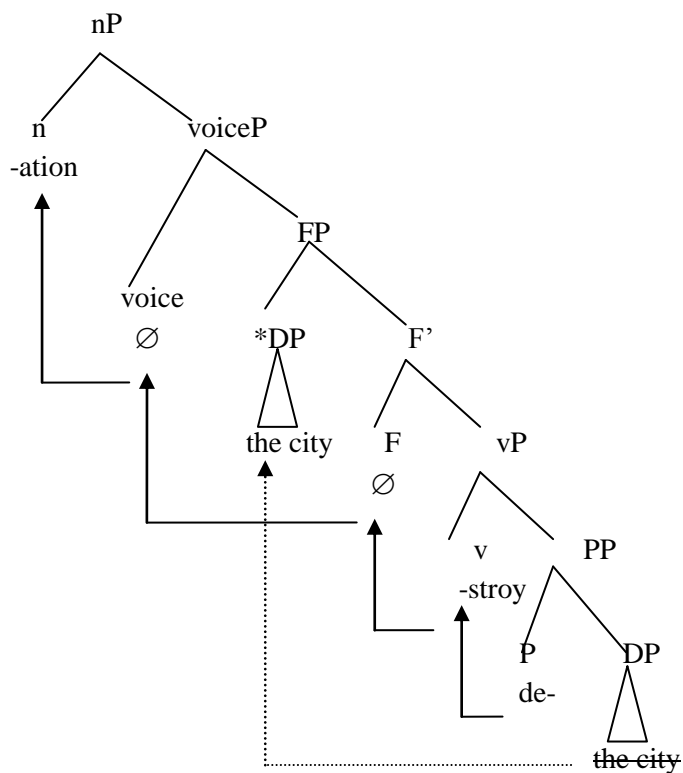

The fact that neither the structure in 95 nor the one in 97 correctly accounts for the structure leaves few options as to the location of *-ation*. It must be higher than where

it is in 94 but lower than where it is in 97. The analysis pursued here will be that *-(a)tion* essentially is a variant of Voice, but a nominalizing one.

There is good reason to assume that *-ation* is a variant of voice. Unlike all other forms of nominalization, derived nominals allow something like passivization. Following Kratzer (1996) the voice-properties of a predicate are housed in the voice phrase. The fact derived nominals allow both a passive and a non-passive variant suggests strongly that there must be something like a voice phrase in them.

98. The Romans' destruction of the city...

99. The city's destruction...

(the city is understood as the destroyed thing)

100. The Romans' destroying of the city...

101. *The city's destroying...

Verbal gerunds do not allow passivization, further suggesting that it is *-ation* itself which is voice in derived nominals. Verbal gerunds must contain an independent voice phrase because they do assign accusative case to their object.

102. *Mary's introducing to the boys....

103. Mary's introduction to the boys...

This is very similar to Ogawa (2001) who argued that derived nominal morphology (which she termed Nz) is analogous to *vP*. However, her analysis does not capture the critical difference between nominal and verbal gerunds -- instead arguing for the proposal that "verbal and nominal gerunds are almost identical and differ only in whether the functional category D selects *v* or Nz" (Ogawa 2001). This proposal has two major problems: First, if there is an Nz present in nominal gerunds (as she argues) how

can we explain the differences in argument structure between nominal gerunds and derived nominals? In fact, while the packaging of the proposal is different it is very similar to the Harley and Noyer (1998) proposal, I have already argued against. The second major problem is that verbal gerunds and nominal gerunds behave very differently (as we have seen) and selectional differences in D cannot explain the differences alone. This discussion will be much further elaborated in the next chapter.

The mystery is then why, if *-(a)tion* is the morphological reflection of nominal voice, does it not assign accusative case to its object, like other voice heads. To that point, we must return to the distinctions drawn earlier between object phrases marked with *of* in derived nominals and object phrases marked with *of* in nominal gerunds. In the former case, the noun phrases can “see-through” *of* and approximate c-command as if there was no preposition (i.e. the preposition is not actually there or inherits the appropriate index), whereas in the latter case the preposition does prevent the noun phrase from binding or licensing an NPI.

It may then be reasonable to assume that these distinct behaviors of *of* are actually reflections of different types of *of*. The *of* seen in derived nominals is the overt morphological realization of accusative case marking in nominals and is thus syntactically transparent²¹. The *of* found in other syntactic environment is a true

²¹ One issue with this analysis would be the apparent violation of Burzio’s Generalization (Burzio 1986) in examples like the following:

1. The destruction of the city...

In this example, *destruction* appears to not have an external theta role but is still assigning accusative case. I would argue that there is still a theta role being discharged to an understood null subject which obviates the violation.

preposition which adjoins and licenses adjuncts. Such an analysis is supported in part by Chomsky (1984), Sproat (1985), Travis and Lamontagne (1987) and Speas (1990) who argue that *of* is not a preposition. The account here is that *of* is sometimes a P and sometimes an overt marker of case. For instance in 104 below, *of* is functioning only as a case marker and does not introduce a PP. In nominal gerunds, *of* is a true preposition²².

With that assumption we can generate a structure that looks very much like the structure of the verbal system, with the exception of the nature of the voice phrase.

Examples like this do raise interesting concerns about co-occurrence restrictions of subjects and determiners within the DP. But these concerns are beyond the scope of this chapter, but will be picked up on in chapter 3.

²² This account does run afoul of DM accounts that attempt to remove all homophony (see Siddiqi (to appear) for an attempt to reduce all of *of* to a single grammatical function). However, given the radically different behavior of *of* in different grammatical environments it is unlikely that a single grammatical function analysis can be maintained.

104. Derived nominal structure

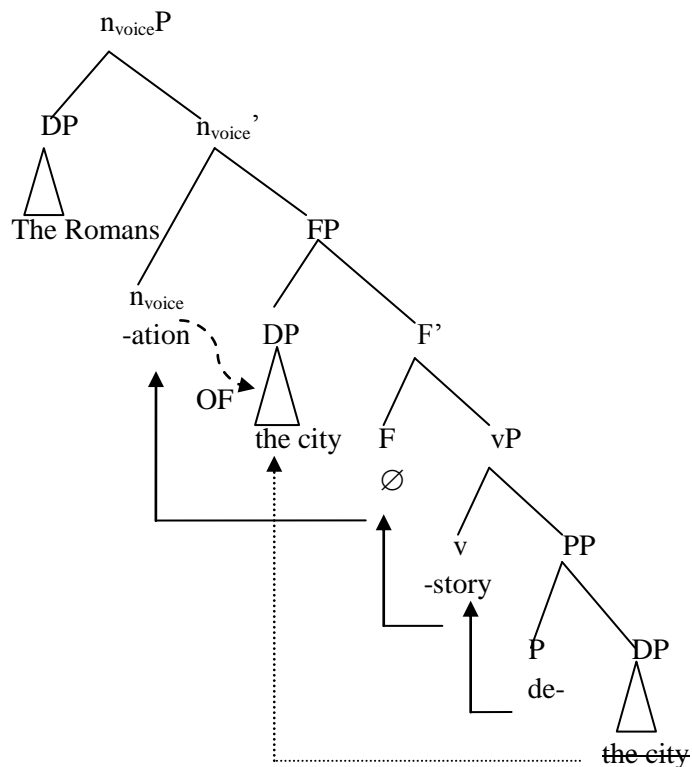

Turning back to examples 49 through 56 (renumbered here as 105 through 112) the lack of binding and NPI-licensing can be easily explained. Nominal gerunds like 105 and 106 require the preposition *of* to license adjuncts.

In all other nominal structures, *of* is an overt case-marker and not a prepositional phrase.

- 105. *John's introducing of the boys]_i to [each other]_i.
- 106. *John's introducing of no boy to anyone.
- 107. John introduced [the boys]_i to [each other]_i.
- 108. John's introduced no boy to anyone.
- 109. John's introducing [the boys]_i to [each other]_i.

110. John's introducing no boy to anyone
111. John's introduction of the boys to each other.
112. John's introduction of no boy to anyone.

This distinction can be seen in the following structures. In 113 *the boys* does not c-command *each other*. Whereas in 0, *the boys* are does c-command *each other*.

113. (Lack of) Binding in Nominal Gerund Structure

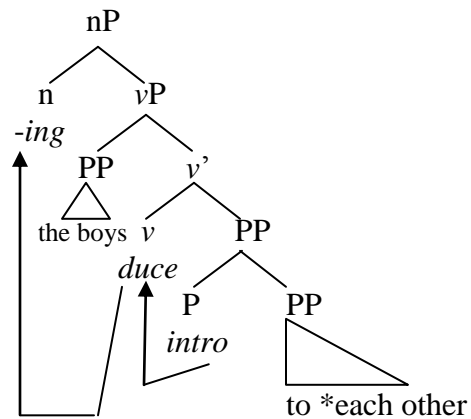

114. Binding in Derived Nominal Structure

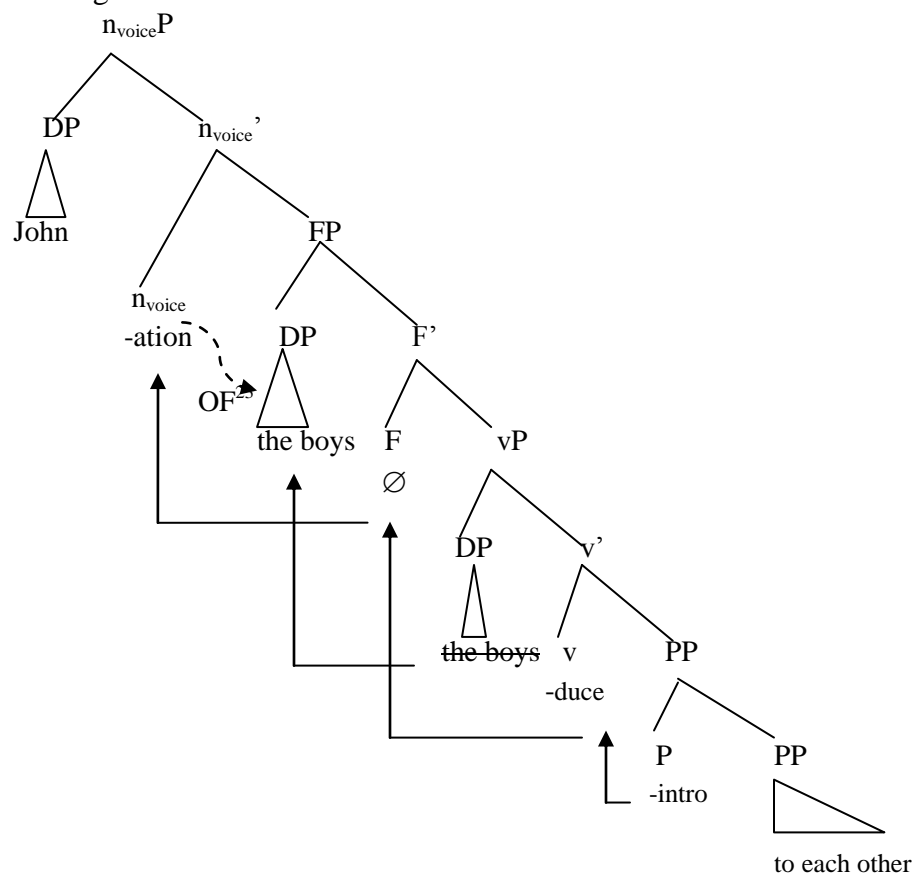

The presence of a preposition alone does not appear to be enough to prevent binding relations in similar constructions. *Picture*-NPs and structurally ambiguous gerunds with other prepositions do show VP-like binding relations across ditransitive objects. This could suggest that theta-assignment is necessary for binding; or, more likely, that adjuncts are extra-planar in some sense (which would also subsume the NPI-facts). The relevant counters can be seen below. *Picture*-NPs likely assign a theta role,

²³ The process by which the case-marker *of* is introduced to the derivation will be discussed in the next chapter.

while non-*of* gerunds are always ambiguous between verbal and nominal gerunds (and verbal gerunds do allow the full range of VP-like relations).

115. John's picture of the boys_j in each other_j's clothes...

116. John's taking to the boys_j about each other_j

Both of the above examples exemplify what has already been show, nominal gerunds behave mysteriously with respect to structural properties and the relationships within them cannot be attributed simply to the presence of the preposition. Rather, it must be a deeper structural/semantic property of root-object relationship.

2.9 Conjunction

Further evidence for the adjunct/argument disjoint between understood objects in nominal gerunds and derived nominals comes from the behavior of these nominal types within conjunction. By hypothesis, I have assumed that both nominal gerunds and derived nominals are headed by same functional category (and label) *n*. Given this hypothesis, we should expect that nominal gerunds and derived nominals should be able to be conjoined with each other (given typical restrictions on conjunction). This is supported by the data.

117. John's picture of the boys_j in each other_j's clothes...

118. The Romans' destruction of the city and pillaging of the village...

119. John's marriage of style and form and joining of elegance and function....

Given that both nominal gerunds and derived nominals are both *n*-projections, the fact that they can be conjoined with each other is unsurprising. However, given the

differences in argument structure between these constructions, we should expect differences to emerge when the conjuncts share an argument. Ross's (1967) Coordinate Structure Constraint (CSC) states that an element cannot be moved out of one part of a conjunct and not the other. This rule prevents structures like the following where an argument of one half of the conjunct is extracted but the other is not.

120. *What did John buy a book and eat *t*?

Crucially, the CSC also prevents the extraction of an argument from one half of the conjunct when the other half *lacks* an argument.

121. What did John live and buy *t*?

In nominals, we see a pattern where when one half of the conjunct lacks an argument (i.e. a nominal gerund) and the other half of the conjunct has one extraction is disallowed.

122. *The Romans' destruction and pillaging of the city...

Example 122 is an example of Right Node Raising (see Postal 1974). The traditional analysis of verbal examples like this is that a copy of the identical arguments is adjoined to the conjunct phrase and the other copies are deleted (still leaving a trace or copy) or that both of the conjunct copies are moved analogous to the *wh*-movement example. Either analysis will make identical predictions for the examples discussed here. Both sides of the conjunct must contain a target for movement (or a null element). Adjuncts may not participate because adjunct positions do not license traces (see Lasnik and Saito 1984).

Derived nominals allow right node raising when conjoined with each other.

123. The Romans' destruction and reconstruction of Carthage...

Nominal gerunds also allow a surface structure similar to right node raising, though because nominal gerunds do not have arguments the apparent right node raised element is in fact just adjoined to the coordinate phrase.

124. The Roman's raping and pillaging of the village...

Because the restriction on coordinate structure only deals with movement operations, there are apparent counter-examples which appear to be mixed coordinations which allow right node raising. Such examples involve the opposite order of nominal type from 122.

125. The Romans' pillaging and destruction of the city...

However, this example is not true right node raising. There is no argument for pillaging. (It could be understood as pillaging of the city or just general pillaging. If this were right node raising the city interpretation would be obligatory.) The appearance of right node raising comes from the surface order, but the example is actually analogous to 117 but here pillaging has no adjunct. There is no movement at all, just the conjunction of two *nPs*.

2.10 A Brief Aside on the Nature of the Contrast

The contrast between nominal gerunds and true nominalization is not very robust for all speakers. The judgments are certainly subtle. However, it is possible to tease apart some of the confounds related to the judgments. All of the issues related to the judgments stem from their relationship to other (similar) constructions: namely, true nominalization and verbal gerunds. I will address each.

One potential reason why some speakers accept binding/NPI-licensing in nominal gerund constructions is the similarity between nominal gerund constructions and verbal gerund constructions. Without modification, the only thing surface difference between these two constructions is the presence of (a phonologically weak) *of*.

126. John's introducing of the boys to each other...

127. John's introducing the boys to each other...

Since 127 is a verbal gerund, the arguments are the licensed by the exact mechanisms that license them in the verbal system. It may then be that the grammaticality of 127 allows the speaker to repair the ungrammaticality of 126. To reach a grammatical form, speakers merely need to ignore a phonologically weak element. The ease by which the form can be repaired may be a reason for a conflict in judgments. However, this hypothesis is speculative and would require further study into grammaticality repair strategies beyond the scope of this dissertation.

Instead, what I offer in this section are other tests which demonstrate that understood object arguments behave differently in nominal gerunds than objects do in other constructions with respect to phenomena that are typically ascribed to c-command relationships.

2.11 Object Opacity

Perhaps the most convincing evidence that these judgments are accurate comes from the behavior of reflexive binding with a gender-matched subject across both forms of gerunds:

128. Mary_i's (quickly) showing Jane_j to herself_{*i/j}...

129. Mary_i's (quickly) showing Jane_j to herself_{*i/j}...

130. Mary_i's (quick) showing of Jane_j to herself_{i/*j}...

Compare the readings in 128 and 129 to that in 130. In both 128 and 129 the anaphor unambiguously corefers with Jane, whereas in 130 it does with Mary. If the argument structure were identical across these different constructions we would expect that they would again behave identically with respect to binding properties. The readings are analogous to those discussed earlier, but with a subtle but important difference.

The example in 130 shows that “object” arguments in nominal gerunds are completely irrelevant for binding. The subject (in this case *Mary*) is able to co-refer with *herself* only because *Jane* does not c-command *herself*.

One of the major issues with these judgments is that beyond being subtle, they are also difficult to construct scenarios that easily fit with the world. However, let us consider the following two scenarios to show that there are plausible circumstances wherein 129 and 130 could be uttered and the appropriate meanings would be understood²⁴. These scenarios are easier to construct if we allow the DP *Jane* to be understood as some representation of JANE (say an image) and not necessarily Jane herself. Such a move does not interfere with the syntax (the binding relations remain the same), but makes the situation more relatable. People seem to rarely exhibit one another (and we seem to talk about doing so even less). It is even less common to exhibit another person to that person or to oneself. However, images as representation do not have this problem.

²⁴ Similar constructions and scenarios could be constructed to show the same pattern with the verb *give*. However, since those scenarios necessarily involve human-ownership, I decided to avoid them.

Situation 1: Jane is a recovered alcoholic. Her sponsor, Mary, keeps a picture of Jane from when she was drinking to remind Jane why she needs to stick with the program. Jane calls Mary during a very hard time asking for help. Mary presents the picture to Jane:

131. Mary_i's (quickly) showing Jane_j to herself_{*i/j} gave her the strength to not drink.
132. Mary_i showed Jane_j to herself_{*i/j}

Note that under this scenario both the verbal gerund and the sentential forms are possible, but the nominal gerund is not permitted.

Situation 2: Jane and Mary are old friends who both have problems with alcohol. Jane has recently run into hard times because of her drinking and she got herself arrested. Mary got a copy of Jane's mug shot (in which Jane looks quite rough) which she carries around with her to remind her why she needs to quit drinking. At a very stressful moment, Mary looks at the picture:

133. Mary_i's (quick) showing of Jane_j to herself_{i/*j} gave her the strength to not drink.

Note that under this scenario neither a sentential or verbal gerund construction would be possible with the appropriate binding relations. This tells us that this construction is somehow fundamentally different than those others (as well as confirming that there is no "hidden" *picture of*-phrase that is altering the binding relationships.

2.12 Negative Polarity and "Action Nominals"

Larson observes (p.c.) that the NPI facts may be anomalous for reasons other than a lack of c-command. Fraser (1970) (see also Zucchi 1993, Katz 1999 and Hamm 1999

for further discussion) claimed that all nominal gerunds, which he terms “action nominalizations” refer unambiguously to events or activities. Because nominal gerunds must be events, the NPI cases could then be argued to be syntactically well-formed but semantically anomalous.

134. #We photographed John’s introducing of no one.

135. #The action of John’s introducing of no one was shocking.

There are good reasons to suspect that semantic anomaly is not the source of perceived ungrammaticality in nominal gerund NPI-constructions. If the event/activity interpretation is the source of the ill-formedness then all irrealis or negative events should be unambiguously ungrammatical for nominal gerunds. Such a prediction is murky at best.

136. John’s introducing of no woman was un-becoming a gentleman.

137. No writing of notes is permitted during the exam

One of the primary problems for Fraser’s account was the syntactic derivation necessary for his analysis was unsupported by the data. In Fraser’s account nominal gerunds contained a high covert action or activity head. However, Wasow and Roeper (1972) showed that such an account fails because an overt activity head is disallowed exactly where Fraser’s covert head must be present:

138. *The {activities/acts/actions} of sighting UFOs worries Mary

139. The sighting(s) of UFOs worries Mary.

140. *John attended a {activity/act/action of} reading *The Bald Soprano*

141. John attended a reading of *The Bald Soprano*
(examples derived from Wasow and Roeper 1972:59)

As I showed in the previous chapter, there are other problems with a pure-action analysis. Following Larson's observation that the lack of NPI-licensing in nominal gerunds (which I attribute to a lack of c-command) may be due to the to a Fraser-style account. Under such an approach, the fact that NPIs could not be licensed would not be syntactic but rather a product of semantic anomaly. Since you cannot have an unambiguous event of a introducing no one the NPI construction must be bad

The problem is still then clearly with the NPI licensing and not with the need for an "action"-interpretation of a situation that would not permit such an interpretation.

It is also unclear to what extent Fraser's analysis bears on the discussion given in this dissertation. As Alexiadou (2001) notes, that for Fraser and subsequent work the critical difference was between gerund-types and not between derived nominals and gerunds. These analyses contrast with Vendler (1967) who argued that the syntactic frame of the gerund and not the nature of the gerund itself were more important for determining the semantic interpretation of the gerund. Alexiadou notes that "derived nominals can almost always replace nominal gerunds" (p. 22, fn i). For Alexiadou (following Fraser), derived nominals and nominal gerunds are both considered action nominals: so if the action analysis is responsible for the difference in argument structure in nominal gerunds, it should also be true of derived nominals. It clearly is not.

2.12 Conclusions

This chapter has shown that there are critical distinctions in the nature of argument structure across different forms of nominalization. It has argued that apparent arguments in nominal gerunds behave nothing like arguments, whereas arguments in

derived nominals behave exactly like arguments of their verbal counterparts. This fact was reduced to case assignment facts due to the syntactic realization of the different heads associated with these constructions.

CHAPTER 3: THAT DEPENDS ON WHAT THE MEANING OF *OF* IS

3.1. Goals

The goal of the short chapter is to resurrect and modernize an old analysis of the disparate behaviors of *of* in English²⁵. The analysis, which traces back to Chomsky (1984/1986), Travis (1984), Sproat (1985), Speas (1986), holds that there are two different forms of *of*: one that is a preposition and one that is a marker of inherent case within the nominals.

This distinction in types of *of* is necessary to explain the differences in c-command relationships between the surface similar forms of nominalization presented in chapter 2 (presented again here). Critically, relationships that are typically analyzed as requiring c-command (binding, NPI-licensing) exhibit different properties in nominal gerunds and derived nominals.

1. *John's introducing of [the boys]_i to [each other]_i.
2. *John's introducing of no boy to anyone.
3. John introduced [the boys]_i to [each other]_i.
4. John introduced no boy to anyone.
5. John's introducing [the boys]_i to [each other]_i.
6. John's introducing no boy to anyone
7. John's introduction of the boys to each other.

²⁵ Many of the theoretical mechanisms used to explain the difference in types of *of* are no longer available in modern theories. D-structure and S-structure have both gone the way of the dodo in the minimalist framework. There is no longer one single derivational point where theta assignment happens nor is there one where Case assignment happens. Both are happening as part of an ongoing derivation and can happen interchangeable.

Constraints like visibility and uniformity are also no longer accepted within the framework and need to be reduced to other more general aspects of the grammar.

This analysis is based on an architectural view that is no longer accepted within syntactic theory. Under the original analysis *of*-the-case-marker is inserted at s-structure to express the inherent case that the argument of the nominal receives from the noun. This inherent case is related to the theta-structure of the verb that the noun derives from (Sproat 1985). There are a couple of issues with this approach that need to be revised. Modern theory no longer has the separate layers of syntactic derivation necessary for a D-structure/S-structure divide. Further, as we will see a theta-based approach is unable to correctly capture the data presented in chapter 2, which is presented again and discussed in this chapter.

After the discussion of these earlier approaches, I present a modernized account of the disparate behaviors of *of*. The goal of this account is to explain the differences between the different nominalization patterns that the earlier approaches could not account for without jeopardizing the data that these analyses could account for. I argue that the Case-marking *of* is the phonological realization of the Case assigned by n_{VOICE} . I show that this analysis correctly predicts the differences in c-command relationships across different types of nominalization while maintaining the insights of Chomsky and Sproat. I also will present a DM-theoretic account of the distribution of *of* based on its featural make-up. Here, I show that *of* is minimally specified allowing insertion as a default in multiple environments.

3.2. *of* in Previous Accounts

Chomsky (1984) proposed a distinction between *of* the inherent case marker and *of* the preposition. Travis (1984), Sproat (1985) and Speas (1990) (among others) offer

similar explanations of the presence of *of* in nominalization environments. I will focus largely on Sproat's (1985) discussion because it is the most comprehensive.

3.2.1 The Model

These accounts were part of the Government and Binding Theory framework (henceforth: GB) (Chomsky 1981, 1983). In GB, the first derivational step was the construction of the D-structure, which was where theta-roles were discharged. To receive a theta-role at D-structure the NP must be theta-governed by the theta-role assigner (usually the verb). Theta-government was defined through m-command so the NP could either be in the specifier position or the complement position of the verb. The entire sentential frame was built during D-structure and almost all of the lexical items were introduced before any movement could occur.

Following D-Structure, the next derivational level was S-structure. S-structure was the locus for many movement operations. It was at this stage of the derivation that Case-assignment needed to be complete. This was either accomplished by obligatory movement to case positions or the insertion of lexical items (i.e., D-Structure — not in a modern DM) associated with inherent case.

From S-structure, the derivation would divide into two separate paths: PF and LF.

Figure 3-1 Government And Binding Model

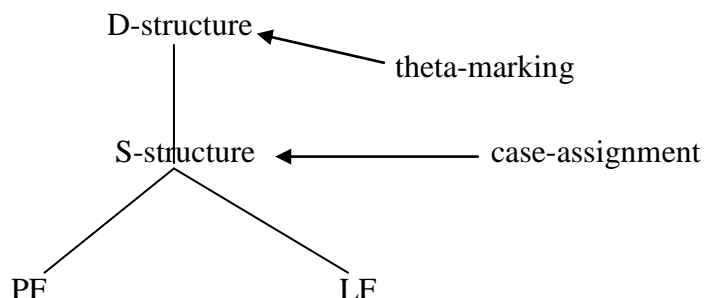

Under this model, there was also a close connection between theta-marking and case-assignment. These connections were caused by two conditions: the visibility condition (Chomsky 1986) and the uniformity condition (Chomsky 1984).

8. Visibility Condition

“A noun phrase can receive a theta-role only if it is in a position to which Case is assigned or is linked to such a position...” Chomsky (1986)

The visibility condition is a condition on chains (linked positions of the NP).

While this condition may seem contradictory to the presentation of the model above, it is not. D-structure still requires the insertion of the NP into its theta-position. But under visibility, theta-roles were not computed until the end of the derivation (at LF).

9. Uniformity Condition

“If **a** is an inherent Case-marker, then **a** Case-marks NP if and only if **a** theta-marks the chain headed by NP.” Sproat (1985)

The uniformity condition is only concerned with inherent case not other forms of case-assignment. Because of the way it is written (Case-marking refers to both Case-assignment and case-realization) the theta position and the Case position must be identical for any inherently Case-marked NP.

3.2.2. *of* as inherent case-marker

Sproat (1985) following Chomsky (1984) argues that the “preposition *of* may be inserted, presumably at S-structure, to realize the inherent Case assigned under theta-government at D-structure.” He argues that the major difference between verbs and nouns is that verbs assign structural Case while nouns assign inherent Case. Under this analysis, whenever a theta-role is assigned directly by the verb the nominalized form will assign inherent Case to any argument NPs. Case assignment in the NP is in no way tied to Case assignment in the VP.

This analysis is supported by the behavior of nominalized unaccusatives. This is seen in the following examples where roots that do not assign accusative Case as verbs still allow *of*-marked objects in nominals.

10. *{It/there} expanded Mark into a gas giant.

11. The expansion of Mark into a gas giant was annoying to the other chess players.

12. {*It/?There} arrived John.

13. The arrival of John cased a commotion.

14. *{It/There} exploded the bomb.

15. The explosion of the bomb was loud.

(Sproat 1985)

Unaccuatives theta-mark their NP complements, but are unable to Case-mark them. If *of*-marking in the NP followed the pattern of Case-marking in the VP we would expect that 11, 13 and 15 would all be ungrammatical. But if *of*-insertion follows theta-

marking then the grammaticality of those examples is completely expected because they are in their theta positions.

3.2.3 Consequences

At first glance, Sproat's (1985) analysis provides the basis for the different *ofs* necessary to explain the divergent c-command relationships presented in chapter 2. For Sproat, *of* that occurs as an inherent Case-marker is a surface-only item and not a preposition (i.e. it does not affect the structural hierarchy) and other instances of *of* are prepositions.

3.3. Problems for Sproat (1985)

Given that Sproat's account is 25 years old, we should expect subsequent inquiry may have provided empirical challenges. The framework has changed enough to render parts of the formal application of his analysis inapplicable today. Again, this is unsurprising given the way that theories evolve and change. However, there is also a major empirical problem for Sproat's account, even if it is modified to fit modern programmatic constraints.

3.3.2 Empirical Issues

Sproat's account is unable to explain the differences in c-command relationships across different nominalization types that were discussed in chapter 2.

Recall that *of* seemed to not be present for the purpose of evaluating c-command for derived nominals, but was for nominal gerunds.

16. John's introduction of the boys to each other.

17. *John's introducing of [the boys]_i to [each other]_i.

Under Sproat's account, there is no way to explain the difference in grammaticality between these examples. Recall that to Sproat the only relevant relationship for Case-assignment in the NP is theta-marking. Both *introduction* and *introducing* would derive from the same verb *introduce*. It would then be expected that its nominal forms would be able to assign inherent Case to its complements. However, it is clear from the structural organization in 17 (the fact that *the boys* does not c-command *each other*) that *of* is not functioning as an inherent Case-marker, but as a preposition.

18. Lack of bidding in nominal gerunds

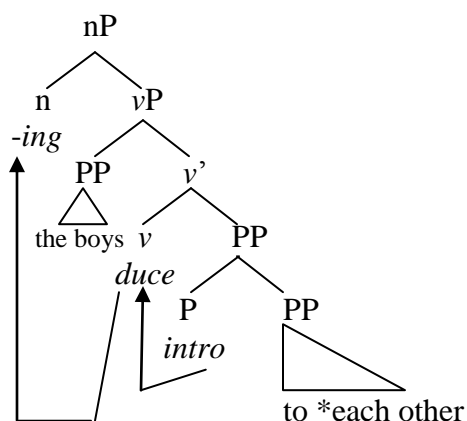

As we will soon see, this issue has further repercussions for Sproat's analysis. Because some forms of nominalization do not use *of* as an inherent case-marker even when the verb would directly theta-mark its object NP, the whole line of argumentation borne out of that insight falls away. I will show that the only reliable diagnostics for whether or not *of* is functioning as a Case-marker or a preposition are the c-command relationships in ditransitives.

3.4. Modernizing the Account

This section outlines an approach to maintaining a distinction between the two different forms of *of* while explaining the nominalization data that the earlier accounts could not handle. The approach given here is built off the structure of derived nominals argued for in chapter 2. I argue that n_{VOICE} is responsible for the assignment of Case within the nominal system, and that the verbal theta-role structure is not what drives the use of *of* as a Case-maker, but there is good deal of (but not absolute) overlap between theta-marking and nominal Case.

3.4.1 Tests for Different Types of *of*

There are a number of complications for testing the prepositional status of *of* in various constructions. By hypothesis, the only instance where *of* is not a preposition is when it is the overt case assigner for an argument of a nominal. However, because extraction out of nominals is highly constrained it is impossible to test whether or not *of* can be stranded in these conditions (as we would expect if it were a preposition) or if it must pied-pipe with the movement of the nominal (which is what would be expected when it is functioning as a Case-marker).

19. *of whom did the Roman's destruction cause great panic?

20. *of the boys, John's introducing to each other cause a panic.

Nor does the behavior of c-command from the subject position into the theme position tell us anything about the presence or absence of a prepositional *of* or a Case-marking of. In both cases the subject c-commands the NP regardless of the presence or absence of a preposition.

21. John's introduction of himself to the ladies...

22. John's introducing of himself to the ladies...

As we saw previously Sproat's generalization concerning theta-assignment by the verbs and inherent Case-assignment realized by *of* also fails as a diagnostic because of the nominal gerunds. This leaves only one reliable way to test for which type of *of* is occurring: c-command relationships in ditransitive nominals.

Because c-command relationships in ditransitives is the only reliable diagnostic for *of* functioning as anything other than a preposition, we must acknowledge that some claims will be speculative because there is no way to confirm or deny the hypothesis. That is to say that we do not necessarily want to produce a theory that assumes the only instances of *of* which are non-prepositional are the direct objects of ditransitive derived nominals. Indeed, I will argue that Sproat's generalization was mostly correct, while acknowledging that is impossible to determine empirically. Much of the generalizing beyond ditransitives follows from an argument from simplicity.

3.4.2 Basics of the analysis

The analysis I argue for in this chapter is a bundle of two hypotheses.

Hypothesis 1: there are two forms of *of*. One is a default preposition the other is the overt realization of nominal Case.

Hypothesis 2: nominal Case is assigned (and only assigned) by *n*_{VOICE}.

I will also argue that *of* is a single lexical item that can be inserted into different syntactic frames. This argument is logically independent from the primary analysis given in this chapter. Neither hypothesis one or two would fail if *of* is found to require

independent (accidentally homophonous) lexical representations. (In fact, hypothesis 1 would be bolstered by such a finding.)

The need for two forms of *of* is apparent from the (now very familiar) distinction between the two different types of nominalization. Arguments of derived nominals exhibit the same c-command relationships as their corresponding verbs, while the direct object argument of a nominal gerund does not c-command (and thus cannot bind or license an NPI) the indirect object.

23. John introduced the boys to each other.

24. John's introduction of the boys to each other.

25. *John's introducing of the boys to each other.

In chapter 2, I argued that the distinction in grammaticality between 24 and 25 is due to differences in the structural make-ups in the two constructions. Derived nominals can assign case (through n_{VOICE}), while nominal gerunds cannot.

However, the need for the two different types of *of* is motivated independently from this analysis. Assignment of Case by n_{VOICE} allows us to capture all of the data from Sproat (1985) without the complications of having to explain why theta-marked nominals do not always receive inherent Case.

Further motivation for n_{VOICE} as a necessary and active part of the grammar is introduced in the next chapter about the grammaticality of various idiom types across the different forms of nominalization.

Notice that when combined the n_{VOICE} and the disparate statuses of *of* hypotheses completely explain the disparate c-command relationships across derived nominals and

nominal gerunds while still maintaining the core of Sproat's (1985) analysis. Derived nominals contain an n_{VOICE} projection and therefore assign Case directly to their direct objects. Gerundive nominals are "cut-off" before reaching the n_{VOICE} projection and are therefore unable to assign Case.

Now even without an empirical way to test the prepositional status of *of* in non-ditransitive derived nominals, we can still conclude that *of* is not a preposition in derived nominals. All derived nominals contain an n_{VOICE} projection. n_{VOICE} projections must be capable of assigning Case to their direct objects to explain the binding facts in ditransitive. Therefore, we should assume that these projections can assign Case in non-ditransitives as well rather than coming up with an analysis that can only explain the ditransitive facts. That would mean that all derived nominals have a structure like the following:

26. Structure of a derived nominal

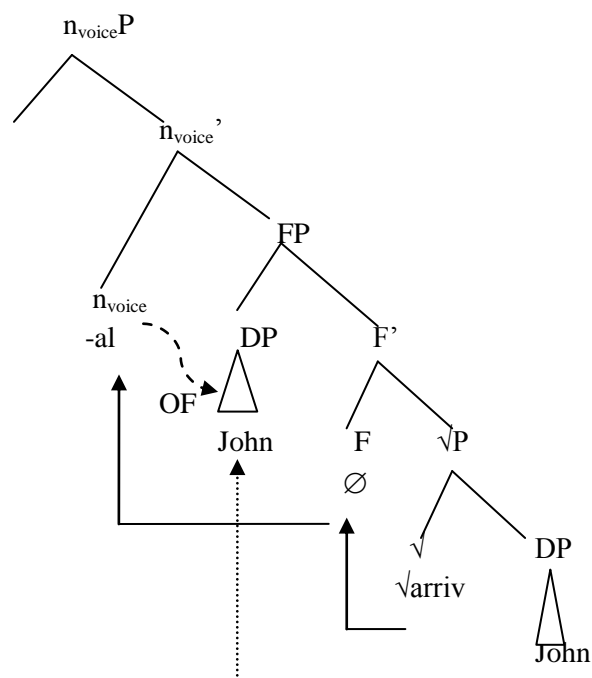

If we assume that there is only one n_{VOICE} in English which is realized differently due to morpho-phonological constraints, this structure allows us to maintain Sproat's insight that Case assignment in nominal and verbal systems are mutually independent. Consider the tree above in 26, based on example 27 below.

27. The arrival of John...

28. John's arrival.

Arrive is unaccuative in the verbal system, but in the nominal system it is identical to transitive predicates because there is only one derived nominal head: n_{VOICE} . This predicts that the Case-marking in derived nominals is identical regardless of how the roots function in the verbal system. The tree in 26 could be any derived nominal structure (with minor modifications). This maintains the general insights of Sproat (1985) without

making reference to theta-marking at all and thus avoiding the problem of the contrast with nominal gerunds.

There are some problems with the preliminary structure offered in 26. The case-marker *of* is inserted through an extra-structural process with undefined properties. Instead let's assume that nominal Case is assigned by a functional head. Following Lamontagne and Travis (1987), termed *k*. However, if we try to insert a structural position for *of* below the *n*-head then we would have a minimality violation when the root tried to head raise into *n*.

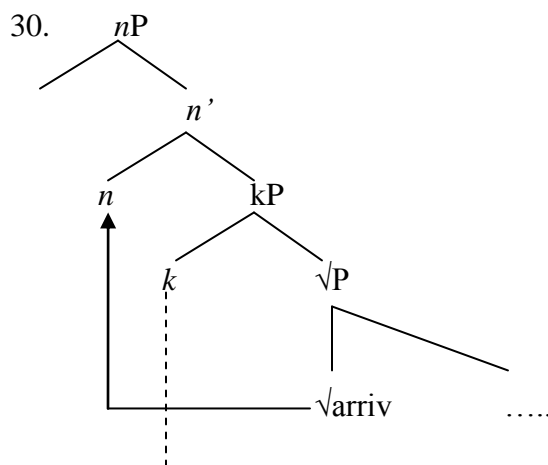

Attempting to head-raise the root into *n* would fail because of the intervening head *k*. The root could cyclicly raise by stopping in *k* before raising to *n*. However, this too would be problematic because *k* would then be pied-piped along with the root into *n*. The appearance of *of* would then be somewhat problematic given that we would have a complex unit composed of *n*, *k* and the root. Given that these items are syntactically fused, they should also be morphologically fused.

If we could show that *of* behaves like a unit with the rest complex root then a cyclic head movement analysis could be maintained. Such evidence does appear in extraction cases.

3.4.3 Extraction and Pied Piping.

Extraction from the DP is notoriously difficult (see Ross's 1967 discussion on NP-Islands), but D(iscourse)-linked phrases (see Pesetsky 1987) are able to escape islands and be extracted. So while nominalizations do not allow extraction under normal conditions, they do allow extraction of D-linked wh-phrases.

31. *What did the Roman's destruction of cause a great panic?

32. Which Mediterranean city did the Romans' destruction of cause a great panic?

Surprisingly, extraction out of nominalizations does not permit pied-piping of the "preposition" *of*.

33. *Of which Mediterranean city did the Romans' destruction cause a great panic?

There is not, however, a general ban on pied-piping of prepositions in D-linked extraction from nominalization.

34. *?To who(m) did John's donation of books prompt an FBI investigation?

35. To which charity did John's donation of books prompt an FBI investigation?

The restriction on pied-piping is thus not a property of extraction of PPs out of nominal contexts, but a restriction on the extraction only of *of* within these nominalized

contexts²⁶. An attempt to analyze this problem as a restriction on pied-piping seems destined to fail — at the very least, any such an attempt would add unnecessary complications to a theory of pied-piping. To my knowledge, there are no other grammatical constructions where English disallows prepositional pied-piping.

A more natural solution would be to argue that this is not an example of pied-piping at all. If we claim that *of* in these examples is not a preposition, then we easily capture the failure of pied-piping in these cases. There are a number of possible analyses of this type that could account for the pied-piping facts. However, given the necessary structural relations from the tree in 30, I will argue that the failure of pied-piping occurs because *of* is not an independent syntactic object in these constructions. Instead, *of* is part of a complex word with the derived nominal (as in [*destruction of*]), and the failure of the extraction is due to the same restrictions on extraction out of a single node found throughout the syntax (“anaphoric islands” in Ross’s terms).

36. *Ing, John was ~~runn~~ing the race.

37. *It was swan that John took Mary on a ~~swan~~ boat ride.

This single-node approach (derived through cyclic head movement) is supported by intonational facts. Pausing is disallowed between *of* and the object of a derived nominal, but is allowed in nominal gerunds and true prepositional phrases.

²⁶ Derived nominals and nominal gerunds exhibit different patterns with regard to d-linked wh-extraction. While derived nominals allow extraction (but only non-pied-piped extraction), nominal gerunds disallow both forms of extraction.

i) *What did the Roman’s destroying of cause a great panic?

ii) *Of which Mediterranean city did the Romans’ destroying cause a great panic?

iii) *Which Mediterranean city did the Romans’ destroying of cause a great panic?

These facts lend support to the adjunct analysis of *of*-clauses in nominal gerunds presented in the previous chapter. Restrictions on adjunct extraction are less violable even with d-linked expressions (see: Pesetsky 1987, Cinque 1990, Baltin 1992)

38. The Romans' destruction of **PAUSE** the city...
39. %The Romans' destruction **PAUSE** of the city...
40. The Romans' destroying of **PAUSE** the city...
41. The Romans' destroying **PAUSE** of the city...
42. The Romans' donation **PAUSE** to society
43. The Romans' donation to **PAUSE** society

Taken together, all of this suggests that derived nominals and the case-marker *of* function as a single unit morphologically; prosodic gaps are disallowed as well as extraction of a sub-piece. A cyclic head movement analysis captures this single unit behavior quite well.

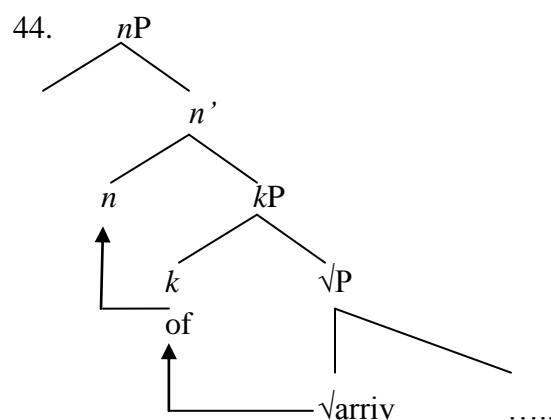

While this analysis can explain why derived nominals and *of* behave more like a single unit than like a noun with a preposition phrase complement, problems still remain. The primary difference between a derived nominal and a nominal gerund is that the *nP* associated derived nominals allows for the functional structure necessary to license a direct object without a preposition. These constructions, which lack a preposition in the

direct object phrase, demonstrate an asymmetric c-command relationship with ditransitive predicates. Nominal gerunds do not. The c-command facts and the differences in the behavior of *of* in these two separate environments seem indisputable. This structure runs afoul of Mirror Principle (Baker 1985) and general DM-ordering considerations and the next section will show that *kP* must be ordered above *nP*, which is closer to Lamontagne and Travis's (1987) original proposal.

3.4.4 Conjunction and the structure order of *nP* and *kP*

Because the elements in *n* and *k* are eventually moved into a single node before morphological insertion, the relative order of the underlying structure seems impossible to ascertain. But conjunction evidence provides a (perhaps) surprising answer: *kP* is above *nP*. This structural relationship allows us to see how nominal gerunds and derived nominals are distinguished by the syntax for morphological analysis, an important fact missing from the discussion given so far.

Recall the structure of a nominal gerund given in the previous chapter:

45. Binding and nominal gerunds

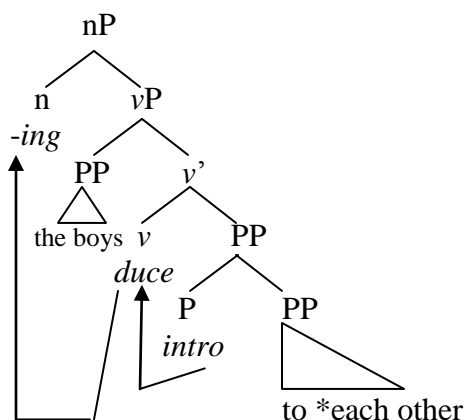

Compare that structure to the structures of a derived nominal headed by *nP*:

46. Derived nominal structure

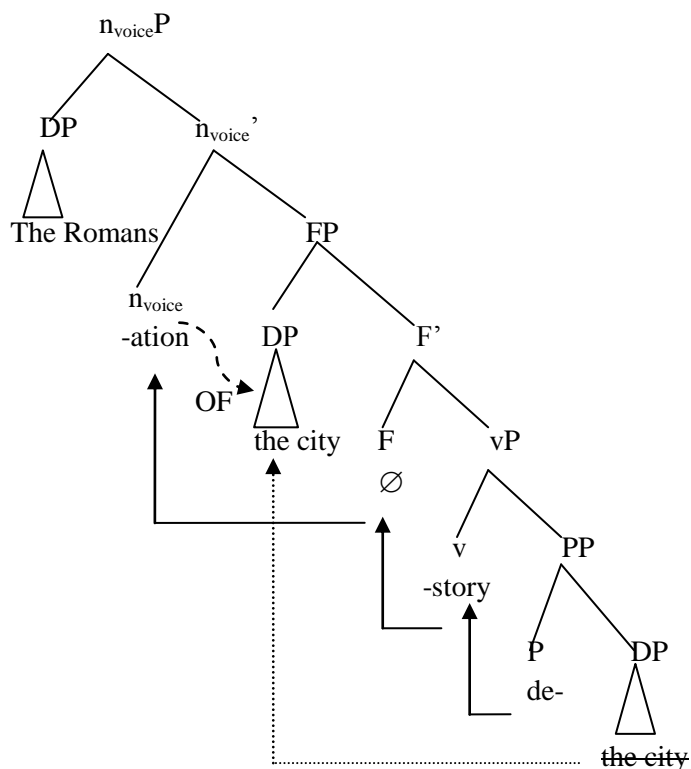

Both trees are ultimately dominated by the same syntactic category. Under virtually all standard analyses of conjunction we would expect that nominal gerunds and derived nominals could co-occur within the same conjunct; however, this is not the case:

47. *The Romans' destruction and raping of the village...
48. The Roman's destroying *(of) and raping (of) the village...
49. The Romans' destruction (of) and reconstruction of the village...
50. The Romans' destroying and reconstruction of the village...

The fact that derived nominals and nominal gerunds cannot co-occur in conjunction is evidence that the structures given above are incorrect somehow. If the

analysis was correct we should expect that conjunction in these cases would be allowed, when it clearly is not. This is not just a problem for the analysis sketched out in this dissertation. Any analysis that assumes the labels of derived nominals and nominal gerunds or identity between the two (i.e. Harley and Noyer (1998)) should also predict that conjunction would be allowed.

The failure of conjunction shows that the maximal category which distinguishes a derived nominal from a nominal gerund must be distinct. Operating on the assumption argued for throughout the last two chapters that the only difference between the two is the presence or absence of a Case-licenser k . If this assumption is true, which the evidence seems to support, then the simplest approach is to argue that the kP is the maximal projection of a derived nominal and that kP dominates nP .

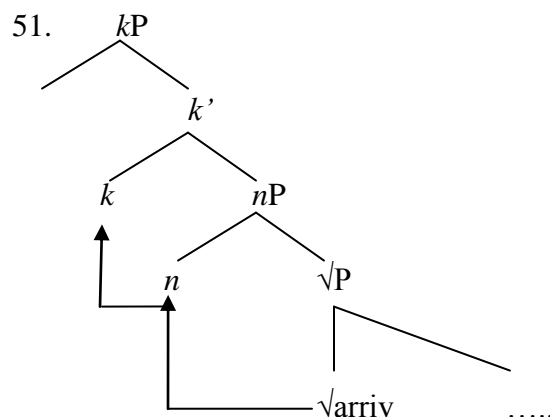

The conjunction facts could fall out of this structure in two distinct ways. If we assume that the conjunction targets the kP , the failure of conjunction is trivial. Nominal gerunds lack the kP . Conjunction requires identical labels and the labels are non-identical.

Alternatively, conjunction could be targeting the nominalizer itself. This essentially run into the same problem as the *kP/nP* mismatched outlined above. Conjunction requires both elements to be featurally compatible at a fundamental level (passives and actives cannot be conjoined in the verbal system, for instance). Thus, it is the nature of the nominalizers themselves that make them incompatible for conjunction.

Both accounts have some morphological issues that need to be accounted for. If the nominalizer is targeted, then conjunction is happening before movement into *kP*. As such, this analysis seems implausible. *kP* conjunction has a further complication in that it would predict that both *ofs* should be obligatory since there are two *kPs* as in the example below:

52. The Romans' destruction (of) and reconstruction of the village...

The optionality of the first *of* is clearly a problem for the conjoined *kP* analysis. But let's take seriously the availability of these two options. This suggests that there are indeed two distinct forms of derived nominal conjunction. Conjoining *kPs* will derive the double *of* examples. But what of the single *of* cases?

Conjoining at the nominalizer could potentially be an explanation. It would, at the very least, explain why there was only one *of* since there is only one *kP*. However, it has some derivational problems that are not easily dismissed. The derivation would start by building two independent word-like structures, and then combine those two structures into one. There are conceptual reasons to believe that an analysis like this is not correct.

Unfortunately, I do not believe that there is a straightforward way to derive these examples without conjunction proceeding head-movement at some step in the derivation.

This may maintain the conceptual problems, but I do believe there is evidence to suggest that such an approach is correct.

So far, we have been assuming that examples like 53 and 54 (below) have identical interpretations.

53. The Roman's destruction of and reconstruction of the city...

54. The Roman's destruction and reconstruction of the city...

However, there appears to be a subtle distinction between conjoined derived nominals that have two *ofs* and those with just one. Those with single *ofs* seem to treat both predicates as part of a single, complex event; there is no distinction between the end of the destruction and the start of the reconstruction. In double *of* conjoined nominals the distinct nature of each event is still present. This suggests that in single *of* conjoined derived nominals the conjunction happens quite low (below any functional structure related to events).

If we assume that conjunction happens at the lowest possible point (the root), then we could potentially avoid some of the conceptual problems. Again, regardless of the proposal, conjunction must happen at some stage prior to or during head movement/word building. However, if we assume that conjunction is conjoining roots then the conjunction would proceed any head movement. The conceptual problem of a conjunct undergoing head movement would remain. But we could then ask if such considerations are necessary in a framework that doesn't hold words as privative. Indeed, it seems quite reasonable that complex elements (like conjoined roots) could undergo such operations.

The morphological structure that would be derived is complex, and currently somewhat speculative. But, if we assume that a complex element [$\sqrt{\quad}$ and $\sqrt{\quad}$] moves into n^0 the appearance of the nominalizing morphology on both elements could be an environmental and phonological consideration; the roots need to be pronounced and they require suffixes to do so. To this effect, the complex element would be simplex from the perspective of the syntax and semantics (thus capturing the single event interpretation) while it is complex from the perspective of the morphophonology. Because *of* is not phonologically required, its single appearance is also explained.

In sum, *kP* is the maximal projection for derived nominalizations. There are two ways to get conjuncts in derived nominals. The first involves conjunction of *kPs* the other involved root conjunction. In both cases, the failure of derived nominals to conjoin with nominal gerunds naturally falls out. The fact that *kP* dominates *nP* will have interesting implications for the morphological analysis given in the next section.

3.5. DM and *of*

In this section, I will clarify what I mean by “two forms²⁷ of *of*.” As noted early, I do not mean to imply that *of* is somehow represented twice as some form of lexical representation. As noted in chapter 1, DM tries to avoid accidental homophony when possible. Despite *of*'s appearance in disparate syntactic environments it is still possible to

²⁷ Though beyond the scope of this chapter, the English partitive construction exhibits yet another arguably non-prepositional use of *of*:

- i. All (of) the boys arrived late.
- ii. All three *(of) the boys arrived late.

only have one lexical entry. The analysis is as follows: *of* is the morphological spell-out of some set of formal features; *of* is minimally specified as shown by its status as an elsewhere preposition. There is only one VI *of* but because of its minimally specified nature *of* is able to appear in many syntactic/semantic environments including positions other than the head of a prepositional phrase.

3.5.1 When in doubt, insert *of*

Although a full featural breakdown of the English prepositional system from a DM perspective is beyond the scope of this chapter, I consider *of*'s place within the flora and fauna of English prepositions. From that discussion, we arrive on a tentative featural breakdown of *of* that explains its distribution. It is clear that *of* is special. The analysis of *of* must capture at least these critical facts 1) *of* must always discharge Case and 2) *of* can occur in environments other than the head of a prepositional phrase. I discuss these points in turn.

3.5.2 *of* and Case

of is the one and only preposition that does not participate in verb-particle constructions or allow null complements. I will argue that both of these facts are indicators that Case is crucial in defining the nature of *of*.

Some analyses of particle constructions hold that particles are categorically prepositions that have been “bleached” of their Case features (see Harley and Noyer (1997) or Ramchand and Svenonius (2002) for a slightly different analysis). Regardless of whether this is the correct way to view verb particles, it is clear that the particles themselves are phonologically identical to prepositions and do not assign Case. The fact

that *of* does not participate in particle constructions could suggest that *of* is inherently associated with Case-assignment.

However, *of* is not the only preposition that does not participate in particle constructions, so generalizing too much from that fact alone is fraught with problems. Prepositions like *with* and *through* also do not participate in particle constructions. But *of* does contrast with all other prepositions that do not participate in particle constructions in that it also does not allow null-objects.

55. John thought of Mary.

56. *John thought of.

57. John came with Bill and Ted.

58. John came with.

59. John drove through the tunnel.

60. John drove through.

Examples 58 and 60 both have contextually-driven null objects associated with the prepositional phrases, the fact that *of* in example 56 cannot have a null object, regardless of contextual-saliency strongly suggests that *of* must always discharge its Case. This restriction on the object position does not extend to movement of Case-marked objects. Such movement (and stranding of *of*) is acceptable as in 61 (below).

61. What was John thinking of?

3.5.3 A tentative feature break-down of English prepositions

The fact that Case is so important to *of* could help us determine the featural make-up of *of* as a vocabulary item. *of* does not seem to contribute any semantic features, so its contributions seem to be limited to case

62. Features of *of* **of** [+Y²⁸ case]

Obviously, there are still some issues with this feature breakdown that are beyond the scope of this chapter. There is the major limitation of the feature breakdown itself; it cannot be just “nominal” case because then we’d still have to explain why *of* sometimes can appear within the verbal system (i.e. *thought of*) but not systematically. If the only feature of *of* were a generic Case feature we should expect *of* to be able to license subjects and objects of all verbs (perhaps optionally). This is clearly not the case. However, *of*’s Case feature cannot be reduced to only the nominal domain because it can surface in the verbal domain as well. For now, I will have to leave the exact specification of *of*’s Case feature a mystery for future research.

Because this feature-specification does not include the category P, *of* is able to appear in a multitude of syntactic positions which fits our criteria that *of* must be able to occur in syntactic environments other than the head of a PP.

63. Features of all other prepositions **P** [+Y, +P²⁹] (where Y is the semantic features associated with the preposition)

Following the observation that all other prepositions besides *of* contribute semantic features, I have included the semantic features in their representations. Doing

²⁸ An abstract feature (still somewhat ill-defined).

²⁹ Prepositional

this provides a critical piece of the *of* puzzle. Because all prepositions are specified for semantic features, whenever semantically unspecified P enters the derivation no preposition is able to be inserted into that position because of the subset principle (all of the prepositions are over-specified). That only leaves *of* as viable candidate.

This means that *of* is not really a preposition like other prepositions. It has no category restrictions and no semantic contributions. This predicts that *of* will be inserted whenever there is not a best-fit preposition that assigns Case.

3.6 Conclusions

This short chapter made several arguments about the distributional pattern of *of*. The crux of this analysis is that *of* is only specified for having some (unknown/abstract) Case feature that allows *of* to be the phonological spell out of nominal Case and be the elsewhere VI for English prepositions.

I also showed that an analysis where the n_{VOICE} projection is the only projection capable of assigning Case in the nominal system can explain the distribution of *of* across the various forms of nominalization while avoiding the problems of Sproat's (1985) theta-role based approach.

Further, this chapter provided deeper evidence for the real distinction between nominal gerunds and derived nominals presented in the previous chapter. Unlike theories which held that derived nominals and nominal gerunds are categorical identical, the account presented in this work accurately captures the failure of these constructions to co-occur in conjunction.

The next two chapters will explore the limitations of the account offered in this chapter and the previous chapter. In particular, I will explore counter-examples to Harley's generalization about Latinate verbs and particles as well as an apparent contradictory finding by Sichel (2010) that nominal gerunds can host more complex events than derived nominals. If this finding holds, it would obviously cast serious doubt on the account provided in this chapter and the previous.

CHAPTER 4: EXPLAINING AWAY *EXPLAIN AWAY*

4.1. Introduction

In this chapter, I argue for a three-way distinction between structural configurations of English verb particle constructions. I follow a modified version of Wurmbrand (2000) and argue that both a small clause structure (Stowell 1981, Kayne 1985, Svenonius 1992, den Dikken 1995, Harley 2008, Basilico 2008, many others) and something like a complex head structure (Booij 1990, Johnson 1991, Koizumi 1993, Stiebels and Wunderlich 1994, Wiese 1996, and Ackerman and Webelhuth 1998, Ishikawa 1999, 2000, Dehé 2002) derive different forms of English particle constructions. I argue that both the small clause structure and the complex head structure are more similar than previously thought; the small clause and the unmodified particle are both selected by the root and the complement of the root.

I argue that Latinate verbs with compound or iambic stress are also forms of particle constructions in English following Harley (2008). I differ from Harley by arguing that though Latinates are particle constructions they are built from a slightly different functional configuration. In the Latinate verbs, the particle (aka the prefix) embeds the root; in most other English particles, the root embeds the particle (or small clause). The argument for this configuration for Latinates is based on selectional properties that can only be attributed to the unprefixated Latinate root.

I also consider the status of the particle-like element *away* that can co-occur with Latinate verbs (contra Harley's 2008 generalization) and otherwise exhibits somewhat

unpredictable syntactic behavior. I show that in many constructions *away*³⁰ is not occupying a particle position — but is in an argument position. It exhibits some particle-like behavior in that it can optionally incorporate (and thus appear on either side of the object). However, it also exhibits properties not typically associated with true particles: it prevents a typically ditransitive predicate from having two objects. Unlike true particles, *away* in this class of examples cannot be modified.

The solution is as follows: first, I show that the roots like $\sqrt{\textit{plain}}$ can select for (a potentially acategorial) head *away*, which projects no structure of its own. Under this circumstance *away* acts like a verb particle with respect to distribution and incorporation, but projects no structure of its own and further reduces the number of possible arguments for the complex verb. Given the lexical nature of this selection, the root $\sqrt{\textit{plain}}$ and the idiosyncratically licensed complement *away* must be merged together. Such a relationship is only possible if the root is embedded by the small clause and not the other way around (contra Harley 2008).

I then consider particle-like uses of *away* in other contexts. I show that *away* in constructions like *dance away the night* is the same *away* that co-occurs with Latinates. This leads to the somewhat surprising finding that *away* and time-spans like *the night* are not a small clause. Arguments from transitivity loss and (the lack of) particle modification are again presented.

Next, I move to an argument that the *away* particle constructions discussed in this chapter and the complex head particle constructions of Wurmbrad (2000) are examples of

³⁰ Like most particles *away* can also project its own small clause. The discussion of the particle *away* in this chapter will focus on when it is a head only.

the same syntactic process: merge of a root with head-only particle. This is shown through the identical modification restrictions on these two constructions and the unselected nature of understood objects, in these constructions but not in the small clause particle constructions.

I conclude with a discussion of ordering in the verbal system and size restrictions on the VP. I argue that the verbal domain is maximally limited to a single small clause-like element, but that there is no ordering requirement of the small clause element with respect to the root. When the small clause is embedded by the root, we get the traditional English particle small-clause constructions. When the small clause embeds the root, we get Latinate-like particle constructions. Altogether these simple differences in the structure allow us to derive virtually all of the English verb particle constructions.

4.2 The Trouble with *explain away*

Studies of the English verb particle construction³¹ have their roots deep in the early generative literature (see Fraser's (1976) typology of the VPC) and have been further developed as in den Dikken's (1995) comprehensive work on the subject. In modern accounts, there has been an attempt to unify the VPC with other complex verbal forms, i.e., with resultatives or with bipartite Latinate structures (see Harley 2008). While this approach has been quite fruitful in accounting for similarities of the different constructions, it fails to fully account for all of the observed phenomena within the English verb. For instance, if Harley (2008) is correct that Latinate verbs and English

³¹ abbreviated VPC

verb particles are essentially the same construction then phrases like *explain away* and *complain away* should be impossible. However, this is clearly not the case.

For Harley, Latinate verbs that have iambic or compound stress are always syntactically bipartite. The foundations of this idea can be seen in Marantz's (1997) proposal that a verb like *destroy* is made up a root \sqrt{stroy} with a prefix *de-* and the long observed phonological restrictions on verb particles (Kennedy 1920, Whorf 1956, Fraser 1965). From this bipartite structure, Harley is able to explain why most Latinate verbs fail to allow dative shift, resultatives and verbal particles. These facts can be seen in the following examples all based off Harley (2008).

Verb Particle

1. Scott wrote up the analysis.
2. Scott wrote the paper up.
3. *Scott composed up the paper
4. *Scott composed the paper up

Resultatives

5. Scott ate himself sick.
6. *Scott devoured himself sick.

Dative Shift

7. Scott showed the problem to Bill.
8. Scott showed Bill the problem.
9. Scott demonstrated the problem to Bill.
10. *Scott demonstrated Bill the problem.

Harley explains all of these facts through a particular structural analysis of the verbs. Latinate verbs fail to allow dative shift, resultatives or verb particles because the two-piece nature of the verb takes up the structural position necessary for these other constructions.

Harley's analysis of Latinate verb constructions is based on the view that particles are the heads of small clause complements to the verb (Svenonius 1992, den Dikken 1995). Harley extends the small clause analysis to Latinate verbs by locating the prefix in the same position as the particle. Thus, Latinate verb construction and VPCs are structurally identical under Harley's view. I follow Svenonius, den Dikken and Harley in assuming the small clause analysis with one major exception that I will come to.

11. Harley's Verb Particle Structure

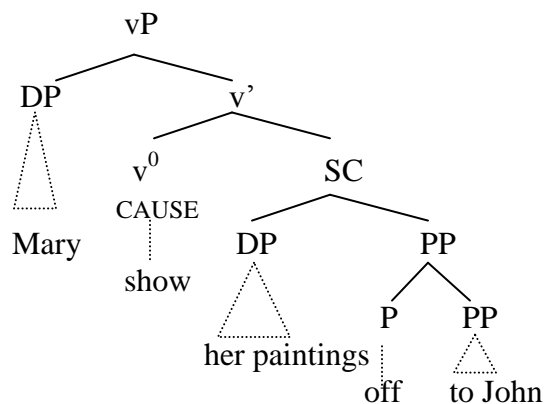

12. Harley's Latinate Verb Structure

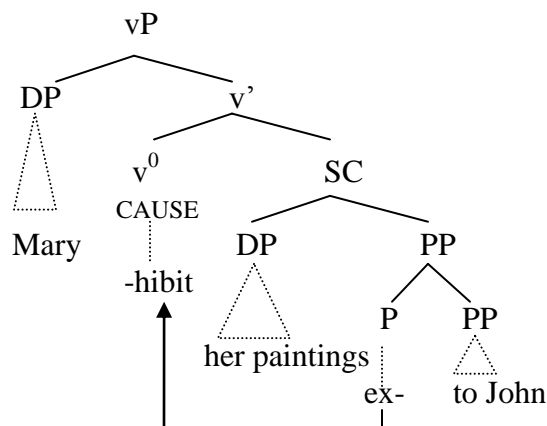

Similar structural accounts explain the Latinate ban on dative alternations and resultative constructions. Dative shift is disallowed following the analysis of the phenomena that has a null P_{have} in shifted forms³². It is not possible to have the null P because the position is already filled by the overt Latinate prefix. Harley further shows that Latinate verbs that *do* allow dative alternations behave prosodically as Germanic verbs. This can be seen in the following examples, which vary in acceptability across speakers:

13. %John *dónated* the library some books.
14. *John *donátéd* the library some books.

³² Basilico (2008) notes an exception to this pattern with verb particle constructions involving benefactive readings.

- i. Bob sent/mailed the stockholders out a schedule.
- ii. The concierge sent the guests up some room service.

(i. & ii. from Basilico 2008 p. 767)

However, these examples fall out from Basilico's larger analysis of the structure of benefactives. Basilico (2008) is clear that these examples (and others like them) "do not challenge Harley's analysis, as [he has] shown above that benefactives do not involve a small clause structure" (p. 767). Instead, these constructions "involve a benefactive-like syntax, with the addition of a higher $v[\text{POSS}]$ head to an already categorized verb" (p. 770).

Under Harley's account when examples like 13 are acceptable it indicates that speakers are no longer analyzing the verb as bipartite and this is reflected in the prosody.

There are gaps in Harley's (2008) analysis of English Latinate verbs as bipartite verbs. While Harley's account can explain why certain Latinate verbs allow dative shift in some circumstances, it cannot account for Latinate verbs that allow particles. Latinate verbs that allow particles do not have the same stress shift as those that allow dative shift.

15. Scott explained away the problem.

16. Scott explained the problem away.

Explain away is a troubling construction for a number of reasons. If Harley is correct in her analysis of Latinate verbs, then the position that *away* would occupy a position already occupied by the Latinate prefix *ex-* (see the structures in 11 and 12).

Explain does behave like a Latinate verb in other circumstances though. It does not allow dative shift or resultative constructions.

17. Scott explained the problem to Bill.

18. *Scott explained Bill the problem.

19. *Scott explained the problem clear.

Again, these results suggest that the verb *explain* is bipartite; therefore, the presence of the particle *away* is a major problem. A closer look reveals even more puzzling data.

Explain allows for distransitive constructions, but no dative shift as we have seen before. However, *explain away* does not allow even a non-shifted distransitive.

20. Scott explained (away) the problem (away)

21. Scott explained the problem to Bill.

22. Scott explained (*away) the problem to Bill (*away).

This behavior is unlike other verb particle combinations that have a verb which allows ditransitives. Ditransitive constructions are not normally blocked by the presence of a particle (though dative shift is). True bipartite constructions allow ditransitives; these apparent “tripartites” do not.

23. Scott showed off his solution to Bill.
 24. Scott showed his solution off to Bill.
 25. *Scott showed off Bill his solution
 26. *Scott showed Bill off his solution.

This failure to allow ditransitives tells us something very important about the structure of *explain away*. We could imagine an analysis that held what was exceptional about *explain away* was the presence of an extra verbal-structural position making the verb *tripartite* in the relevant sense. The structure of that would be the following:

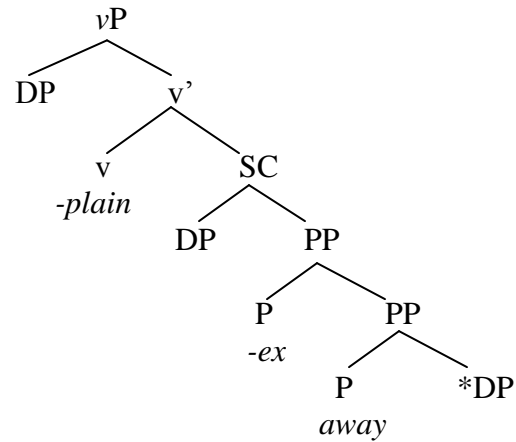
27. Impossible Tripartite Structure of *Explain Away*

However, such an analysis would make the wrong prediction about the number of arguments that *explain away* would allow. *Explain away* should allow at least two object arguments. Instead, it only allows one. The reduced number of arguments suggests that instead of being an extra level of verbal projection, the particle is occupying one of the positions that an argument would normally occupy. Such a structure would look like the following:

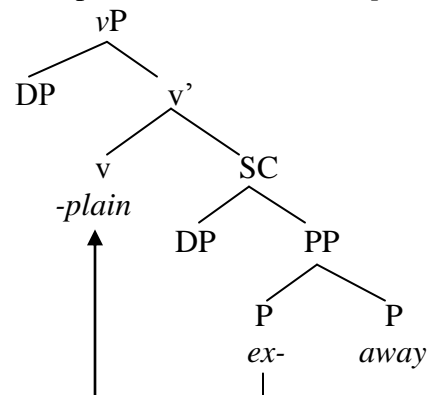
28. “Tripartite” Structure of *Explain Away*

In this structure, the “particle” *away* is in an objection position (i.e., is the complement of the predicative element *ex-*). *Away* is not a predicate itself and therefore has no argument position. Its presence blocks the addition of an additional argument.

This behavior shows that English verbs are still maximally bipartite at the relevant point of structure. (I make no claims about the number of verbal projections allowed at higher structural positions such as *voice*.) But the fact that English verbal projections are bipartite still leaves a major problem: How can verbal particles (or particle-like elements) be present in a maximally filled verbal projection?

I argue that a structure like 28 can account for the distributional facts with one minor modification: a Harley-style structure cannot explain why some roots can co-occur with *away* while others cannot since *away* and the root are not in a local relationship. If the relative order of the root and the small clause are reversed, this fact is readily explained.

29. Structure of *Explain Away*

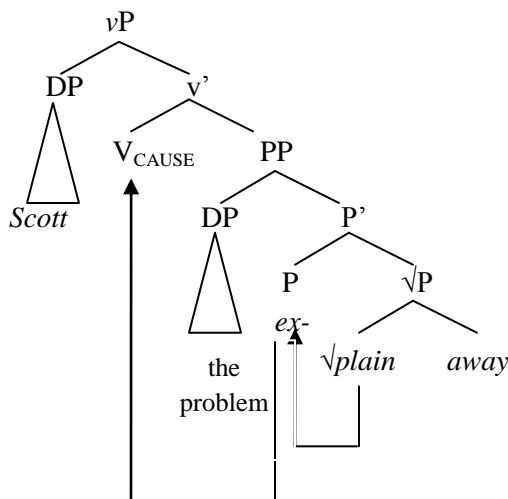

The structure provides the basis for the rest of the analysis. The absence of the second argument in ditransitives is due to the particle occupying the position where the

argument would need to be. The root can select (or not select) for *away* because it begins the derivation merged together. Further, this structure also can account for the apparent loss of transitivity in temporal consumption uses of *away* with one simple assumption about object licensing.

30. The Vikings were pillaging *(villages) the night away.

To motivate the structure in 29, I must first show that the distributional facts are presented and that the appearance of *away* is associated with properties of individual roots and not with a more general pattern.

4.3 *away* as a Small Clause Particle and as a Non-Small Clause Particle

In this section I examine the syntactic distribution and interpretation of *away* in various constructions to show that *away* exhibits some but not all properties of small clause particlehood when paired with the certain Latinate roots (like \surd *plain*). These semi-particle properties will lead to an analysis of *away* in these contexts as a part of a complex head structure wherein *away* in complex predicates like *away* will have a small clause structure.

4.3.1 *away* as a Small Clause Particle

Away appears in a number of disparate verbal contexts — including many non-small clause usages. It is thus necessary to tease apart all potential usages of *away* and show that in constructions like *explain away* it exhibits behavior like, and is interpreted like, a verb particle.

4.3.1.1 *away* as a True Small Clause Particle

Away appears in numerous unambiguous verb particle constructions. Like other particles *away* allows ditransitives (though not dative shift³³) to be reordered with respect to the object and can be modified by elements like *right, all, the hell/the heck* (Fraser 1976, Ramchand and Svenonius 2002).

31. John kissed (away) the tears (away) **(reordering)**
32. John gave (away) his possessions (away) to the church.
(reordering/ditransitive)
33. John threw it (right/all/the hell) away. **(modification)**

Under any distributional test of particlehood, it is clear that *away* can function as a particle with some predicates.

4.3.1.2 Other Uses of *away*

There are numerous surface similar uses of *away* that are not particle constructions. *Away* has several adverbiallike uses, including: a sense of immediate action or relative spatial position.

34. Fire away! **(immediate action)**
35. John kissed Bill *(right) away. **(immediate action)**
36. John turned away from his mother. **(spatial position)**

A further use, which could potentially be viewed as adverbial (complete temporal consumption) will be argued to be another example of VPC, surprisingly subject to the same constraints.

³³ Follows Harley's (2002, 2008) analysis of Dative Shift through a silent P_{HAVE} particle.

37. John danced (away) the night away. (temporal consumption)

As the next section shows, *away* in Latinate verbs does not exhibit any of the adverbial behaviors, but does show some behaviors of particles.

4.3.1.3 *Away with Latinates*

When *away* co-occurs with Latinate verbs it may occur on either side of the object. It is important to note that many of the following examples appear to be subject to speaker variation. This is not unexpected if my argument that *away* is licensed by idiosyncratic properties of certain roots holds. Whenever possible, I have used a published source for at least one half of each example pair. Even as such, universal acceptance of these examples is unexpected.

38. Harvard study says poverty doesn't **explain away** low American math scores³⁴.
(Yahoo! News headline 8/22/11³⁵)
39. Harvard study says poverty doesn't **explain** low American math scores **away**.
40. How to **complain away** bad moods.
(CBS News online photo gallery³⁶)
41. How to **complain** bad moods **away**.
42. One of the philosophers **calculated away** the possibility.³⁷

³⁴ A reviewer notes that elements other than particles can exhibit the same distributional patterns as particles:

- i) John broke the jar open.
- ii) John broke open the jar.

This fact is not one that my account can explain. While this may suggest that the technical details concerning incorporation presented later in the chapter may not stand, even if *away* is undergoing some type of resultative shift akin to *open* in the above examples, its presence is still unexplainable given Harley's account of Latinates. Most of the technical details offered in this analysis would hold even if *away* is a pseudo-result and not a particle—save the incorporation.

³⁵ <http://news.yahoo.com/blogs/lookout/harvard-study-says-poverty-doesn-t-explain-away-214057461.html>

³⁶ http://www.cbsnews.com/2300-204_162-10006832.html

³⁷ Based on this quote: "Again, while the *Great Western* steam-ship was on the stocks at Bristol, one of the philosophers at the meeting of the British Association, which at the time was held in that city, calculated

43. One of the philosophers **calculated** the possibility **away**.
44. ...They would be obliged to **analyze away** the intention of going to jail...
(Gaylin 2001 pg 260³⁸)
45. They would be obliged to **analyze** the intention of going to jail **away**.

Crucially, while several Latinate verbs are capable of co-occurring with the particle, *away* does not appear to be a generalized exception to Harley's account. Numerous (if not the majority) of Latinate verbs cannot co-occur with *away*. Again, there is some level of expected speaker variation. It is worth noting that none of the above examples are receiving any adverbial type interpretation as outlined in the previous section.

46. *Barry composed (away) the mess (away)
47. ?*Heidi concealed (away) the blemish (away)
48. *The Romans destroyed (away) the city (away)
49. ?*Sylvia discarded (away) the leftovers (away)

A close look at the above examples also make it increasingly clear that a clean semantic division between Latinates that accept *away* and Latinates that fail to is unlikely to be found. This suggests that *away*'s ability to co-occur is a property of the individual roots it co-occurs with and not with lexical or other properties of *away* itself. Though, that statement may be too strong because *away* does appear to be the only exceptional particle³⁹. Perhaps then these exceptions are best characterized as being an interaction of lexical properties.

away the possibility of the steamer ever crossing the Atlantic." From, Timbs, John (ed.). 1864. *A Century of Anecdote from 1760-1860*. pg 115.

³⁸ Gaylin, Willard. 2001. *How Psychotherapy Really Works*. Contemporary Books: Chicago.

³⁹ Mark Norris (p.c.) notes that *away* is generally the most semantically homogenous of verb particles.

Overall, there appears to be some idiosyncratic Latinate forms that allow *away* to co-occur with it. When *away* does co-occur, it exhibits some distributional properties which are identical to true particles. However, *away* also displays behavior different than true verb particles.

4.3.2 *Away* is not a (true) particle (when with Latinate)

As discussed in section 1, when *away* co-occurs with a typically distransitive Latinate verb, distransitivity becomes impossible. This is not a general property of *away* in VPCs:

- 50. Scott explained the problem to Bill. **(Latinate distransitive)**
- 51. Scott explained away the problem *to Bill **(Latinate distransitive)**
- 52. Homer gave his possessions to Bart. **(non-Latinate distransitive)**
- 53. Homer gave away his possession to Bart. **(non-Latinate distransitive)**

Further evidence for a distinction comes from the modification of the particles themselves. Fraser (1976) noticed that some particles can be modified by elements like *right* (akin the English adverbial *right away*), *all* and *the hell/the heck* can modify the verb particle itself (see also Ramchand and Svenonius (2002)).

- 54. I'll look the information right up.
- 55. The iron pier rusted right away. (under the appropriate reading)
- 56. They cleaned it all up.
- 57. The housewife dusted them all off.
- 58. ?He bawled the boys all out.
- 59. They cleaned the room all up.

60. He had fished the pond all out before noon.
61. The wrecking crew tore the building all the way down before noon.
62. Don't dent the car all in if you want to sell it.
63. I'll look it the hell up after I finish eating.
64. Turn that light the heck off.

(54-64 all taken from Fraser (1976 p. 26-27))

Verb particles with complex Lantinate verbs, like *explain*, do not allow any modification.

65. *John explained the problem right away. (under the appropriate reading)
66. *John explained right away the problem.
67. *John explained the problems all (the way) away.
68. *John explained all the way away the problems.
69. *John explained the problem the hell away.
70. *John explained the hell away the problem.

Note that this is not true for all VPCs with *away*. It is possible for *away* to be modified when it is part of a verb particle construction that does not contain an already complex verb (see 55 above and the examples below).

71. John threw it right away. (under the appropriate reading)
72. John threw it all (the way) away.
73. Throw it the hell away!

Taken all together, the facts suggest that the apparent particle *away* is not in the position generally occupied by particles (head of its own small clause). Instead, *away* is merged directly with the root, which explains both why the second argument of ditransitives is lost and why *away* cannot be modified in these constructions.

4.4 The structure of English verb particle constructions

Recall Harley's VPC structure given in section 1.

74. Harley's Verb Particle Structure

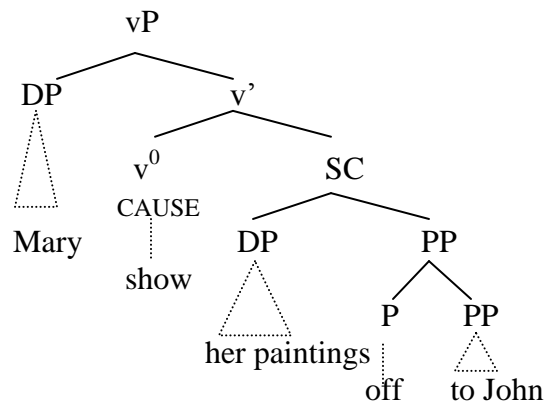

75. Harley's Latinate Verb Structure

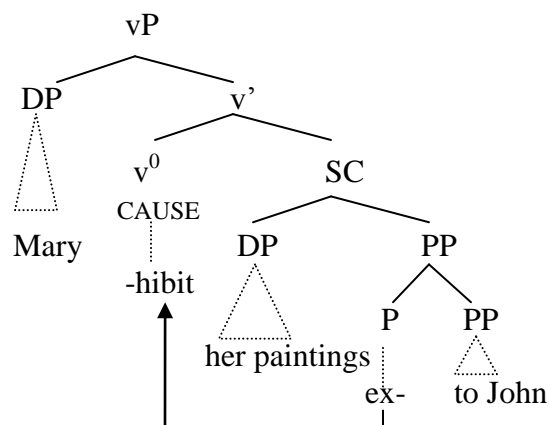

Taken together, these structures provide a nice symmetry between the bipartite structure of Latinate verbs and the verb particle constructions. However, this structure

makes precisely the wrong prediction with respect to the licensing conditions of particles like *away*. If we assume that *away* occupies the same position as the PP *to John* in the structure in 75 then we would expect that the prefixial head of the small clause in Latinate verbs to be the source of *away*-acceptability. However, it is quite clear that *away*'s presence or absence does not depend on which prefix heads the clause.

- | | | |
|-----|---------------------------------|--------------------|
| 76. | *John composed the mess away | (coN- head) |
| 77. | John complained the ticket away | (coN- head) |
| 78. | *John exhibited his fears away | (ex- head) |
| 79. | John explained the crises away | (ex- head) |

Further, by projecting the root directly into v_{CAUSE} , Harley seemingly suggests that overt bipartite verbal structures cannot have other flavors of v . Though given the recent explosion of flavor projections and the sometimes ill-defined boundaries between v and *voice*, ascribing such a claim to Harley may be unfair. Regardless, it is clear that other flavors (such as passive⁴⁰) are compatible with particle constructions.

80. The ticket was complained away.
81. The paintings were shown off.

Within DM, roots must move from their initial position to a x -head to receive category. Thus, it is not unreasonable to assume that Harley's structure is impoverished (not including both *voice* and the separate verbalizing head v). Indeed, embedding the

⁴⁰ This point is not meant to be a claim that Harley's v_{CAUSE} and passive must occupy the same head. It is merely an observation.

root within the small clause will allow us to explain the local-selection effects and still capture the correct surface order.

82. Root embedding Latinate structure

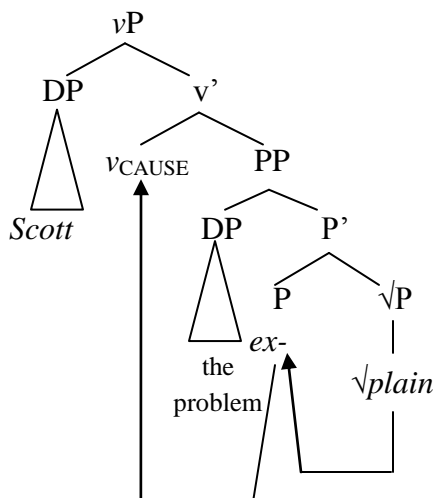

The above structure essentially flips the relative order of the particle/prefix from the structure offered in Harley (2008). The structure has a number of advantages to the one Harley presented in 2008. First, by embedding the root within the small clause the local relationship between a root and its complement required to account for (the lack of) co-occurrence with certain Latinate roots and *away* is present. These can be seen in the following structure.

83. Root embedding Latinate structure with particle

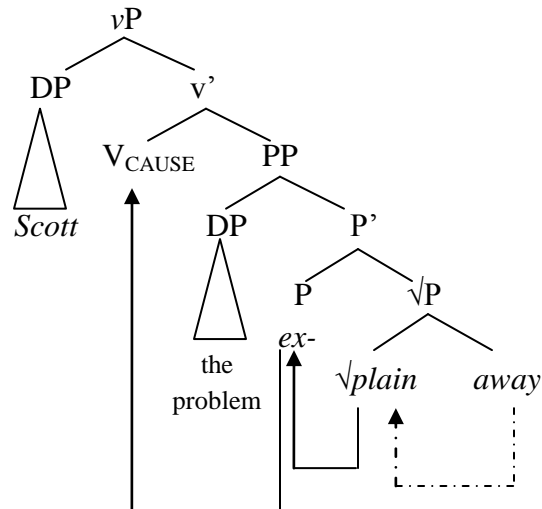

One unfortunate consequence of this analysis is that the mirroring of Latinate constructions and other English verb particles is lost to a certain degree. If the structure offered in 82 is extended to non-Latinate particle constructions, we would predict that particle incorporation is mandatory.

84. Illicit structure of non-Latinate VPC

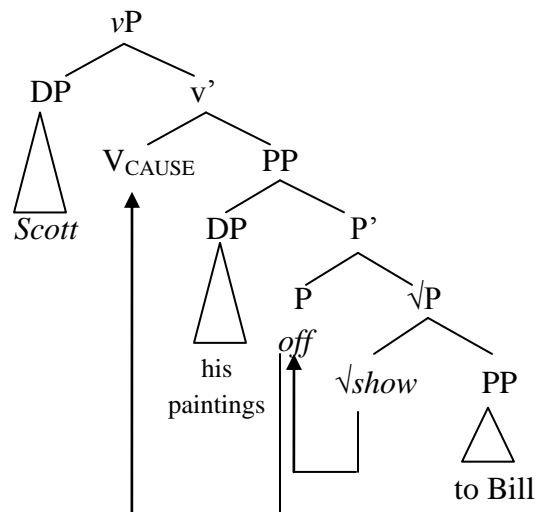

This forces us into the seemingly unsatisfactory position of having to posit distinct structures for Latinate verbs and verb particle constructions. While this may appear to be a limitation of the analysis, there is good reason to suspect that it is correct.

First, we see no double-particle constructions analogous to Latinate plus *away* constructions. This fact readily falls out if the *root* is already selecting for the small clause and is thus unable to also select for extra particles like *away*. And if roots are selecting for full small clauses, we should also expect to find verb-small clause idioms (assuming that idiomiticity is an inherently local relationship, loosely following Marantz 1984 and subsequent). This prediction is borne out.

85. John will bring up the rear.

86. Jeremy put in a brief appearance.

(85 & 86 den Dikken 1995:p. 92)

87. give up the ghost

88. throw in the towel

89. pull out all the stops

90. throw out the baby with the bathwater

(87-90 Greg Key (p.c.))

Thus, we are left with two separate structures for verb particle constructions. The one in 82 where the “particle” is a prefix and idiomaticity is not found — the structure of Latinates. The other where the root embeds the SC, particle incorporation is optional and the verb small- clause idioms can be found.

91. Structure of non-Latinate VPC

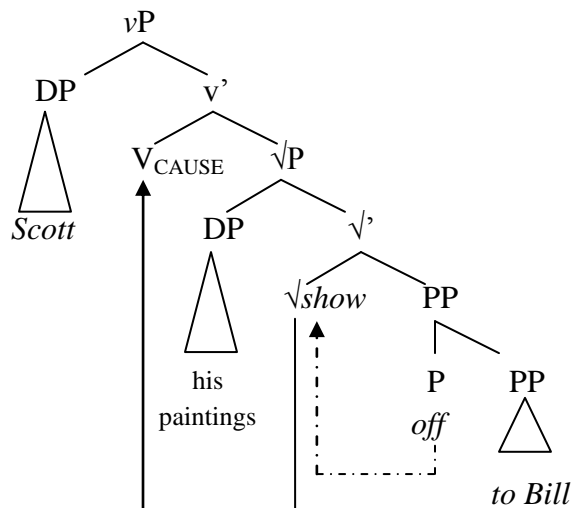

There is some evidence that the structure offered for Latinates in 83 is not limited to Latinates at least for some speakers. Non-Latinate prefixal particle constructions (such as *downplay*) allow *away* for some speakers, but not in the roughly semantically equivalent nonprefixal constructions.

92. %Peter downplayed (away) the claims (away)

93. *Peter played down away the claims

This suggests that for some speakers, non-Latinate prefixal-particle constructions are structurally identical to Latinate constructions.

The appeal to distinct structures for particle constructions is certainly not novel in discussions of particles. Wurmbrand (2000) argues for two distinct structures for West Germanic particle constructions⁴¹. Wurmbrand distinguishes semantically transparent

⁴¹ Ishikawa 1999, 2000 similarly argues for a two-structure approach to particle constructions in English. Ishikawa does not adopt the small clause analysis of particle constructions but has a lexically derived, complex head structure for “pure idiom type” particle constructions and a verb-PP complement (containing only the particle) structure for “simple combination types” and “hybrid combination types”.

particle constructions from idiomatic ones. In this analysis, transparent-particle constructions are small clause structures akin to those argued for by Stowell 1981, and further developed by Kayne 1985, Svenonius 1992, den Dikken 1995, Harley 2008, Basilico 2008 (among many others). The idiomatic particle constructions are built out of a complex V'-structure (analogous to the complex head proposals of Booij 1990, Johnson 1991, Koizumi 1993, Stiebels and Wunderlich 1994, Wiese 1996, and Ackerman and Webelhuth 1998, Dehé 2002 — who argue for lexically derived complex head structures — or van Riemsdijk 1978, Baker 1988, Koopman 1995, Olsen 1995, Zeller 1997, 1998 — who argue for an incorporation analysis).

94. Small Clause Structure (Wurmbrand 2000)

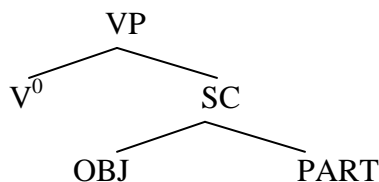

95. Complex Head Structure (Wurmbrand 2000)

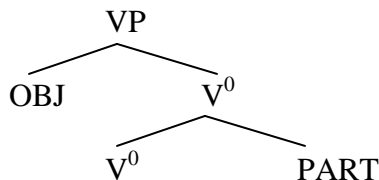

With this analysis, Wurmbrand accounts for a number of disparate facts in West Germanic-particle constructions. Wurmbrand argues that particles with a small clause

Ishikawa's distinction between pure idiom particle constructions and simple combination/hybrid constructions does not align with Wurmbrand's seemingly similar distinction in West Germanic. English particles generally resist topicalization—a critical diagnostic for Wurmbrand.

Given the small clause idioms discussed above, I assume that if there are multiple verb particle constructions, at least one must be a small clause.

structure have fully transparent meanings, allow contrastive particles, and allow scrambling/topicalization of the particle or the particle and the object. Particles in the complex head structure exhibit none of these properties.

While many of these phenomena are not directly applicable to English particles, the structures proposed in this chapter are basically identical to Wurmbrand's (save the flipped order in Latin constructions). Structures containing the argument-eating particle *away* are examples of Wurmbrand's complex head construction.

If this is true, then we should expect that other particle constructions argued to complex-head constructions should behave identically with respect to the tests offered in this analysis (failure of modification, argument loss for the predicate). This is exactly what is seen. If we consider Ishikawa's (1999, 2000) complex head example *take in* (as in deceive), we see that the particle *in* cannot be modified and reduces the number of arguments that *take* can have.

- 96. The crook took (in) the marks (in)
- 97. #The crook took the marks right in.
- 98. #The crook took the marks in from their money⁴².

Though the tests are different, the disparate behavior of particles in a complex head structure and particles in a small clause structure is exactly in line with Wurmbrand's analysis. In the next section, I address one critical test from Wurmbrand to distinguish between small-clause particles and complex head particles: the particle-

⁴² Contrast with:

- i) The crook took the money from the marks.
- ii) The crook took the marks from their money
- iii) The charity took (in) the orphans

object relationship. In particular, I argue that objects of complex head particle constructions are unselected by the verbal root or the particle.

4.5 Unselected Objects: Temporal *away* and Complex Head Particle Constructions

Further evidence for the account offered in three comes from the particle-like behavior of *away* in its temporal consumption use. It is possible (following Jackendoff 1997) to analyze this use of *away* as a particle since it is possible to get *away* to occur between *dance* and *the night*.

99. John danced away the night.

There are a number of differences between *away* in these constructions and other particles. Unlike other particles, *away* in this use can occur with any predicate provided that it is atelic or can be coerced to be so (such as progressives). While *away* can intervene between the verb and the time span, it may be questionable to treat this time span as an object.

100. John chatted (away) the meeting (away)

101. The Vikings were pillaging (away) the night (away)

102. The mathematicians were calculating ?(away) the night (away)

However, this use of *away* also strongly disprefers the presence of any object — even generic plurals compatible with atelic predicates.

103. ?*The Vikings were pillaging villages (away) the morning (away)

104. ?*The mathematicians were calculating problems (away) the night (away)

Perhaps most surprising, the temporal *away* has the exact same co-occurrence restrictions in Latinate verbs as the particle *away* discussed previously.

105. ?The professor was explaining away the night.

106. Bill was complaining the night away

107. ?*Beethoven was composing away the night

108. *The Romans were destroying away the night.

This strongly suggests that there are selectional restrictions on *away* regardless of interpretation. Roots that can select for *away* can have it in particle constructions or in temporal consumption constructions. This means that *away* occurs in the same position in both structures. If this is the case, the time span must be occupying the position that the direct object would occupy. Adopting such a structure explains why a predicate-like *complain* goes from being distransitive to having no true arguments.

109. *Bill explained the problem to Johnny away the night.

110. *Bill explained the problem away the night.

111. *Bill explained to Johnny away the night.

Essentially, the argument is that time spans (and by extension) other objects of complex head particle constructions are unselected objects (in the sense of Levin and Rapoport 1988). However, unlike other unselected objects that occur with small clauses, the entire complex predicate predicates the argument (where in a small clause only the small clause predicate does).

This structure is identical for both Latinate structures with the temporal *away* and with the particle *away*. Meaning that *away* in both contexts is functionally identical.

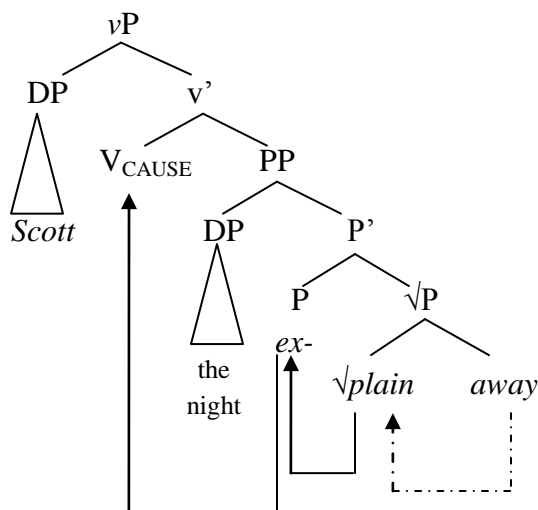
112. *Away the night* with Latinates

4.6 Restricting the Size of the Verbal Domain

One thing apparently lost from Harley's (2008) analysis of Latinates is the general failure of Latinates and particles to co-occur. Harley treated the Latinate prefixes as particles in the same position as the Germanic particles in other constructions. Thus, the explanation for their lack of co-occurrence is simply that multiple elements cannot occupy the same position. But in the analysis I have argued for in this chapter, Latinate prefixes occupy a slightly different structural position than Germanic particles. Selectional requirements forced the analysis of the relative position, but the co-occurrence restrictions are now less clear.

The solution I propose is quite simple. Event/verbal projections are limited in a fundamental way. The lowest levels of the verbal projection — which I assume to be the root and the small clause (when one is present) — are maximally capped at these two elements. Order is not relevant. Latinates cannot co-occur with small clause-particle

constructions, because they are composed of a small clause. The thrust of Harley’s explanation therefore remains. Latinates don’t co-occur with small clause particles for the same reason that small- clause particles don’t co-occur with other small clause particles — there can only be one small clause.

An explanation of why multiple particles generally cannot exist in English falls out of this analysis as well. As we have seen, only when the small clause embeds the root (Latinates, *downplay*) can an additional particle be present (if selected for). Multiple particles (be they multiple small⁴³ clauses, multiple heads or a combination of the two) cannot exist elsewhere because there is no position available for them to occur.

4.7 Conclusions

In this chapter, I motivated a three-way structural distinction between particle constructions in English. I argued, following Wurmbrand (2000), that both the small clause and complex head structures of particle constructions are extant constructions in English. I also argued for a third construction type, which is related to the small clause structure; Latinates (and perhaps other prefixal particle constructions) are small clause constructions with one critical difference: the small clause embeds the root.

Particles like *away* can co-occur with Latinates because they do not project small clauses. Rather, head-only particles occupy an argument position, reducing the transitivity of the roots with which they co-occur. This is true for *away* constructions and for the “pure idiom type” particle constructions of Ishikawa (1999, 2000).

⁴³ Though ruled out for independent reasons.

This analysis provides further evidence for Wurmbrand's (2000) argument that multiple distinct structural forms can exist for particle constructions simultaneously in the same language. The analysis also captures the heart of Harley's (2008) generalization about particles with Latinate verbs as well as explaining the cases that Harley could not.

There are a number of natural extensions to this work. First, it is an open question to what extent these structures are available cross-linguistically. Can these structures account for the well known distinction in the general availability of particle constructions in Germanic versus their unavailability in Romance? What language specific properties determine what types of particle constructions are available; for instance why does Italian seem to permit complex-head particles while French does not (see Masini 2005)?

In English, the picture is clearer. There are three different available structures, and these structures may even interact with one other. Non-prefixal small clause particle constructions cannot co-occur with complex head particles because both the particle head and the small clause need to occupy the same position. Prefixal small clause particle constructions and non-prefixal small clause particle constructions cannot co-occur because multiple small clauses exceeds the maximal size of the verbal projections. Prefixal small clause particle constructions and complex head particle constructions can and do co-occur.

CHAPTER 5: MORPHOLOGICAL CONSPIRATORS: MORPHO-SYNTAX AND THE APPARENT EVENT-STRUCTURE DIFFERENCES ACROSS FORMS OF NOMINALIZATION

5.1 Introduction

Sichel (2010) noticed a major difference in the types of events permitted in nominal gerunds and derived nominals. She noted derived nominals only allow simple events while nominal gerunds allow for a more robust set of event types (for example resultatives).

Many of Sichel's arguments relate to the ways in which nominalized forms (both derived nominals and nominal gerunds) differ from verbs. These arguments will not be under discussion here. What is relevant to our discussion is Sichel's claim about event-size and type of nominalization. Sichel argues nominal gerunds are capable of hosting larger, more complex, events in contrast with derived nominals, which cannot:

“English derived nominals are restricted to single, simple, events, while ING-OF gerunds can also host complex events, in particular, lexical causatives and augmented events of various types” (Sichel, 2010: 2).

This of course would be a major challenge to the proposed structural analysis I offered in chapter 2. In that chapter, I argued nominal gerunds were syntactically *less* complex than derived nominals. However, if we adopt a view that event-structure and syntactic structure are correlated in any way (Borer 2005, Ramchand 2007), then the structures given in chapter 2 should not produce *more* complex events in nominal gerunds. Obviously, severing event-structure from syntactic structure would be a radical step, requiring significant evidence.

The solution I offer in this chapter is simple: nominal gerunds do not allow more complex events than derived nominals. The appearance of more robust event complexity is actually a conspiracy of the morpho-syntax. The morphology prevents the syntactic realization of some event types, but there is nothing inherently wrong with complex events in derived nominals. Indeed, following Harley (2008) I argue that Latinate bipartite verbs (which form the bulk of English derived nominals) are complex events of the relevant type.

Sichel (2010) notes some major differences between the event structure of derived nominals and nominal gerunds. The basic fact can be reduced to the following statement: nominal gerunds allow complex events while derived nominals do not. Sichel notes that complex verbal expression (resultatives, particles) are permitted in nominal gerunds but not in derived nominal. This can be clearly seen in the following (all taken from Sichel 2010a):

1. *John's explanation (away) of the problem (away)
2. John's explaining (away) of the problem *(away)
3. The running thin of the pavement⁴⁴
4. The barking awake of the neighbors

For Sichel, the restriction on particles and resultatives in derived nominals is a reflection of restrictions on event-complexity within the construction.

⁴⁴ Sichel (2010, in press) offers slightly different examples as grammatical:

- i) the running of the pavement thin
- ii) the barking of the neighbor's awake

The grammaticality of these examples was questioned during the University of Arizona colloquium series talk and both Sichel and the audience agreed the examples in the chapter are much better and that the examples listed in this note are questionable at best.

5.1.1 Problems for the Accounts Offered in this Dissertation

If Sichel's analysis is correct, details of the accounts I have offered in the previous chapters of this dissertation come into serious question. First, consider the differences between nominal gerunds and derived nominals discussed in chapter 2. There, I argued derived nominals allow for a more robust argument structure. If Sichel is correct, then there is a major mismatch between derived nominals and nominal gerunds: nominal gerunds would be restricted in argument structure but not event structure and derived nominals would be restricted in event structure but not argument structure. While this would certainly not be a fatal problem, it would be puzzling to say to the least, especially under an approach that attempts to tie arguments and events to syntactic configuration.

The event-based approach would also pose a very serious problem to Harley's (2008) analysis of English Latinate verbs and thus would call into question the account given in chapter 4, since the analysis was built assuming most of the details of Harley's account. Recall that in Harley's account, the English Latinate verb is bipartite in structure and that this bipartite structure is at least analogous (if not identical too) resultatives and particle construction. Harley is able to explain why (for the most part) resultatives and particles are impossible with Latinate verbs. In chapter 4, I offered an account of the exceptional cases that Harley was unable to explain and extended parts of the analysis to zero-derived nominals.

However, if derived nominals disallow resultatives and particles due to restrictions on their event-structure, shouldn't they also disallow all bipartite Latinate verbs? This

would seemingly be the case if Harley and Sichel were both correct. But, Latinate verbs in fact are robustly found in derived nominals (see discussion in chapters 2 and 4) and perhaps provide the bulk of the predicates for that construction. Clearly, something has got to give.

5.1.2 Derived Nominals and Morphology

To account for apparent restriction on particles and resultatives in derived nominals, I compare the morphology of the different forms of nominalization and not their event structure. I show all of the effects that have been attributed to differences in the event structure can be derived through standard assumptions of Distributed Morphology.

In particular, I argue the bulk of the failure to allow resultatives and particles in derived nominals follows from Harley's (2008) analysis of Latinate verbs. Latinate verbs mostly⁴⁵ disallow particles and always disallow resultatives. This follows from Harley's bipartite structure where the positions that a particle or resultative would normally occupy are already occupied by pieces of the verb (see discussion in chapter 4). Given that the bulk of derived nominals are Latinate, this explanation readily explains most of the derived nominals.

The more interesting problem is the behavior of particles in the few Latinate verbs that allow particles and all Anglo-Saxon verbs under the different forms of nominalization. There, we see a major difference between derived nominals and nominal gerunds. Derived nominals disallow all particles. Nominal gerunds permit them. I argue

⁴⁵ The exceptions are explained in chapter 4.

the difference is morphological. I argue that in all forms of nominalization, incorporation of the particle into the predicate root seems to be required. In addition, this incorporation can interfere with the morphological ordering, rendering some constructions impossible. Though, this is not a problem for zero-morphs.

It is a problem for derived nominals because incorporation must occur before movement into the n^0 which houses the nominalizing suffix. Since incorporation has occurred the complex element of the predicate root plus a particle is moving into the position. The nominalizer cannot attach to the predicate root because the particle interferes. Thus, the restriction on particles can be reduced to a purely morpho-syntactic explanation.

Surprisingly, it does not appear to be an issue for nominal gerunds with particles. Particles can easily occur in nominal gerund constructions. But they too have overt nominalizing suffixes, so why then are particles allowed to occur? To explain that, I turn to Bobajlik's (1994) (based somewhat on Halle and Marantz (1993)) account of English tense suffixes. They argue English tense morphology joins its host post-syntactically. (Such an explanation is needed to explain why English particles can optionally incorporate into the predicate root.) Using that account, I slightly modify the structure of nominal gerunds that I offered in chapter 2. I argue the nominal gerund suffix *-ing* also joins the root post-syntactically. I further argue the distinction between the two types of suffixes is natural in English given that *-ing* appears to be a post-syntactic suffix in the verbal domain as well.

Finally, I discuss the lack of resultatives in Anglo-Saxon derived nominals. I argue that the issue appears not to be with resultatives and the derived nominal construction itself but rather with resultatives and the predicates that can occur in the derived nominal construction; that is, that it is a property of the predicates that disallows resultatives and not the construction itself. And further, given the sparseness of Anglo-Saxon derived nominals, drawing many conclusions from this potential accident may be unproductive.

5.2 A Typology of Particles, Arguments and Nominalization

Derived nominal, nominal gerunds and zero-nominals show a three-way distinction among the acceptability of particles and arguments. As discussed in chapter 4, zero-derived nominals allow both arguments and particles—but never at the same time⁴⁶. In zero-derived nominals, arguments can never co-occur with a particle. Derived nominals disallow particles in all circumstances regardless of the presence or absence of an object argument. Nominal gerunds show the reverse co-occurrence restriction with respect to object-arguments and particles. In nominal gerunds, particles can only occur when the object is overt.

Particles and Objects in Zero-Derived Nominals

5. John turned over the knife.
6. John's turn over (*of the knife)...
7. John's turn of the knife...

⁴⁶ Though, as noted in chapter 4, object-arguments themselves are uncommon in zero-derived nominals.

These examples show the co-occurrence restriction on particles and objects in zero-derived nominals. Both particles and objects are permitted independently (as seen in examples 6 and 7), but they cannot occur together. It is worth noting again that, in general, objects are dispreferred in zero-derived nominals. This fact is largely unimportant, but does stand in sharp contrast to the behavior of (overtly) derived nominals. Those constructions (discussed below) disallow all particles but allow object arguments.

Particles and Objects in (Overtly) Derived Nominals

8. John explained away the problem
9. John's explanation (*away) (of the problem)...

The presence or absence of an object is irrelevant to the allowability of particles.

Particles are always disallowed in (overtly) derived nominal constructions. In contrast, nominal gerunds have no issues with particles. Nominal gerunds are limited in the position that the particle can occupy (in contrast to the verbal system).

Particles and Objects in Nominal Gerunds

10. The repairman turned on the lights.
11. The repairman turned the lights on.
12. The repairman's continuous turning on of the lights [drove the electric bill way up this month]
13. * The repairman's continuous turning of the lights on [drove the electric bill way up this month]
14. John explained the problem away.
15. John explained away the problem.

16. John's explaining away of the problem

17. *John's explaining of the problem away

The examples above show that the particle must be adjacent to the verb and to the left of the object. The example in 16 also shows that while the derived nominal form of *explain away* is impossible, the nominal gerund form is possible. It is examples like these that form the core of the event-based approach to nominal constructions. But is there another way of explaining why the derived nominal form is impossible while the nominal gerund form is acceptable?

5.3 Morphology, Nominalization and Particles

In this section, I make three distinct arguments about the impossibility of resultatives and particles in derived nominal constructions. First, I argue the bulk of the unacceptability of these constructions in derived nominals stems from the way that the nominalized element is built. Most derived nominals are Latinate and following Harley (2008) already composed of a bipartite morpho-syntactic structure that does not leave room for either particles or resultatives. Thus, the unacceptability of most forms can be reduced to already-explained phenomena in the verbal system. I then turn to the problematic Latinate plus particle constructions that I discussed in chapter 4. These forms (like *explain away*) are true Latinate bipartite verbs but still allow particles, which is unexpected given Harley's (2008) proposal⁴⁷. These constructions can appear in nominal gerunds, but not in derived nominals. Clearly, a story based entirely on Harley's (2008) analysis will not suffice. Instead, I offer a morphological explanation: I argue

⁴⁷ In chapter 4, I offer an account of these constructions. The details of that analysis are not relevant to the discussion in this chapter.

that particles in nominalization appear to require incorporation; however, incorporation is incompatible with the morphological structure of derived nominals and not of nominal gerunds.

Finally, I turn to Anglo-Saxon derived nominals. I argue that the same morphological explanation offered for forms like *explain away* can be extended to the lack of particles in Anglo-Saxon derived nominals. Resultatives also seem to fail to appear in Anglo-Saxon derived nominals. To account for this, I show that the predicates that can occur in Anglo-Saxon derived nominals fail to allow resultatives in all other constructions. This suggests that the ban is not a property of the construction itself but perhaps an accident of a very small sample.

5.3.1 Harley 2008 Revisited

For a detailed account of Harley's (2008) proposal see the discussion in chapter 4. Here, I intend only to sketch out the generalization Harley makes in that paper about particles and resultatives with bipartite Latinate verbs. That generalization is simply put: resultatives and particles are incompatible with Latinate verbs because the structural position that the result or particle would occupy is already filled by the Latinate prefix.

Harley argues that Latinate verbs have a bipartite structure analogous to resultatives and particle constructions. Essentially, this means that your average Latinate verb is actually a particle construction. In Latinate verb constructions, the Latinate prefix occupies the same structural position as particles. The structures for both constructions are given below.

18. Harley's Verb Particle Structure

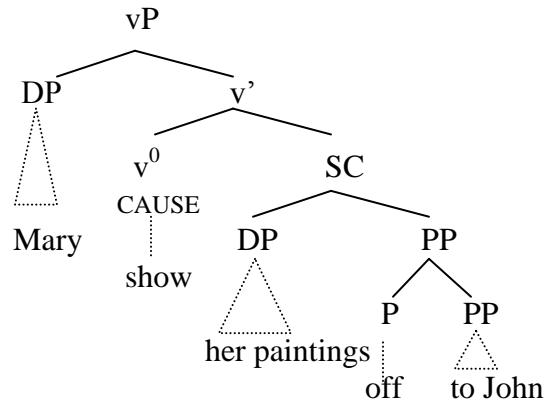

19. Harley's Latinate Verb Structure

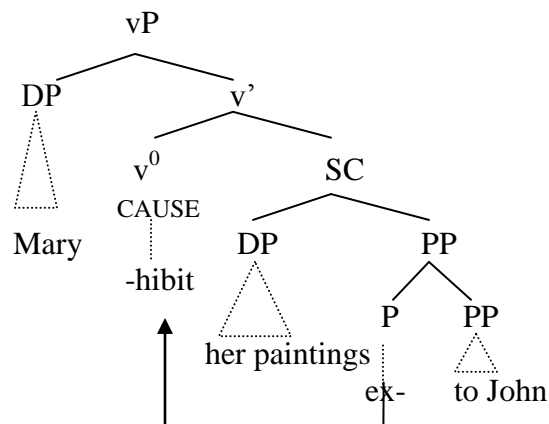

For our purposes, there are two things critical to this analysis. First, if Harley is correct and Latinate verb structures and particle verb construction structures are identical, then the claim that derived nominals are limited in event-complexity faces a serious challenge. If Latinate verbs and particles are actually the same type of construction, we should expect no difference in event-structure.

This analysis also provides a simple explanation for the bulk of “missing” particle constructions and resultatives in derived nominals. Those constructions are incompatible with Latinate verbs, which compose the lion’s share of derived nominal constructions.

Consider the modified list of verb particle and resultative constructions from Harley (2008), here modified to include the derived nominal form for all of the Latinate verbs.

20. Verb particle constructions (from Harley 2008)

| Anglo-Saxon | Latinate | Derived Nominal |
|--------------------|----------------------------------|-------------------------|
| write it up | *compose it up/*arrange it up | composition/arraignment |
| eat it up | *consume it up | consumption |
| finish it up | *complete it up | completion |
| throw it out | *discard it out | * ⁴⁸ |
| lie down | *recline it down | reclination |
| hand it out | *distribute it out | distribution |
| show it off | *exhibit it off / *reveal it off | exhibition/revelation |
| fire it up | *ignite it up | ignition |
| slice it off | *incise it off | incision |
| tidy it up | *arrange it up | arrangement |
| hide it away | *conceal it away | concealment |
| cut it apart | *dissect it apart | dissection |
| figure it out | *calculate it out | calculation |
| move it over | *displace it over | displacement |
| go away | *depart away | departure |
| clear it up | *clarify it up | clarification |
| cast it off | *release it off | * |
| dig it up | *excavate it up | excavation |
| swell up | *expand up | expansion |
| trade it in | *exchange it in | * |

⁴⁸ There are Google results for both *discardment* and *discardation* but neither seems to be in widespread use.

21. Resultative Constructions (from Harley 2008)

| Anglo-Saxon | Latinate | Derived Nominal |
|----------------------|-----------------------------|-----------------|
| fill it full | *inflate it full | inflation |
| walk yourself tired | *perambulate yourself tired | perambulation |
| work yourself ragged | *decide yourself ragged | decision |
| squeeze it empty | *compress it empty | compression |
| stab it dead | *impale it dead | impalement |
| freeze solid | *congeal solid | congealment |
| dance yourself pink | *exert yourself pink | exertion |
| eat yourself sick | *devour yourself sick | ??devourment |
| scrape it raw | *abrade it raw | abrasion |
| burn black | *combust black | combustion |

What is critical about these examples is not just that the Latinate forms from which the derived nominals are derived disallow particles and resultatives but that the Anglo-Saxon forms all do not have derived nominal forms. And, there may also be a ready explanation for this fact. Recall the discussion of the morpho-syntactic requirements of *-(a)tion* from chapter 2. *-(a)tion* requires a bipartite stem:

22. Fridtjof Nansen's winterization of the equipment made the expedition possible.

23. *Fridtjof Nansen's winteration in Tucson was an annual treat.

Even an Anglo-Saxon root like *winter* can be nominally derived by *-(a)tion* if mediated by the overt verbalizer *-ize*. *-ment* appears to have a similar requirement on stem size. Since bipartite structure is mostly incompatible with particles and completely incompatible with resultatives, the bulk of the arguments about events in derived nominals can be reduced to a purely morpho-syntactic explanation: derived nominals are generally already structurally equivalent to particle constructions. The lack of particle constructions falls out of the lack of available structure, not available events. There are nominalizers other than *-ment* and *-(a)tion*; I discuss these in section 5.3.3. below.

5.3.2 Distributed Morphology, the Mirror Principle and Particle Incorporation

We have seen why most derived nominal plus particle constructions (and all resultative) can be ruled out independently of an event-structure based analysis by following Harley's (2008) analysis of Latinate verbs. Most English derived nominals are derived from Latinate verbs (for instance all *-(a)tion* nominals). Their bipartite structure is incompatible with particle/resultative constructions. However, as discussed in chapter 4, it is possible to get true bipartite constructions with particles; even when a particle in the verbal equivalent is allowed bipartite derived nominals do not allow particles.

24. John explained away the problem.

25. *John's explanation away...

Clearly, this is a problem. Examples like 25 seemingly support an analysis based on event-type. However, I will argue that the problem with 25 is not eventive but morphological. The critical piece of the puzzle lies in the required position of particles in nominal gerunds. In nominal gerunds, particles must always be adjacent to the root even in the presence of an object. This contrasts with particles in the verbal domain which are freer in their position (occurring either next to the (moved) root or finally). Following the standard analyses of particles (Svenonius 1992, den Dikken 1995, Harley 2008, Bascilico 2008), I assume when the particle is root adjacent it has incorporated into it. For reasons that I leave for future exploration, this incorporation seems to be mandatory in nominal constructions. It is the requirement on incorporation that drives the ungrammaticality of 25. Derived nominals are morphologically incompatible with incorporation for reasons discussed in the next section.

Root+Particle Orders in the Verbal Domain

- 26. John explained the problem away.
- 27. John explained away the problem.
- 28. John kicked the game off.
- 29. John kicked off the game.

Root+Particle Orders in the Nominal Gerunds

- 30. *John's kicking of the game off...
- 31. John's kicking off of the game...
- 32. *John's explaining of the problem away...
- 33. John's explaining away of the problem....

According to the Mirror Principle (Baker 1985), morphological ordering and syntactic ordering must match. This principle is a natural consequence of the morphological and syntactic identity in a theory like DM. However, both derived nominals and nominal gerunds appear to violate this principle if we assume that the particle is incorporated. Particle incorporation happens before any movement to the nominalizer, but the morphological ordering would be root-nominalizer-particle. This is clearly not an issue for derived nominals, because the result is ungrammatical. But, what of nominal gerunds? What separates the morphological processes in derived nominals from those in nominal gerunds? To answer that, I will first turn to English tense.

Tense behaves similarly to the nominalizing *-ing* in nominal gerunds with respect to ordering and particles. Many English particles can optionally incorporate into the root. Since tense is located quite high in the syntactic structure, the incorporation of the

particle precedes any merger between tense and the root. However, the surface order is root-tense-particle⁴⁹. This surface order is exactly analogous to the “illicit” order found in nominal gerunds.

It has long been observed that English tense behaves differently than other morphological categories. Within DM, Halle and Marantz (1993) and Bobaljik (1994) both argue for a version of the “lowering”-analysis. Under these analyses, the verb never raises into T^0 . Instead, the tense morphology finds the verb post-syntactically. The relationship between a head and its affix “need not in all cases be derived in the syntax or the lexicon” (Bobaljik 1994:26). For Bobaljik, affixation not derived in the syntax is derived through PF linear adjacency (with some stipulations about adjuncts and arguments).

While roots and incorporated particles are a single syntactic head, they each are still independent phonological elements. That means that when the tense affix is looking for its host at PF the verb without the particle is visible. This allows us to skirt around the apparent Mirror Principle violations.

Bobaljik’s approach focused largely on the behavior of English tense affixes, but the original discussion of lowering/affix hopping operations involved a wider range of verbal morphology. In Transformational approaches, the affix-movement rule applied generally to auxiliary/verbal suffixes. Consider the following examples below (from Emonds 1976: 206). Here, the affix rule targets all of the suffixes in the (a) strings and moves them to their surface positions in the (b) strings.

⁴⁹ Obviously, this is a simplified template, focusing only on the relevant pieces of morphology. Many elements (such as the verbalizer) are left off.

34. (a) John-ed-have-en-take-the course
 (b) John-have+ed (had)-take+(en)-the course
35. (a) The girl-s-be-ing-play-the trumpet
 (b) The girl-be+s (is)-play+ing-the trumpet

Bobaljik's approach to English tense can be easily extended to modernize Chomsky's (1957) account of English verbal morphology more generally.

A similar analysis can capture the allowability of particles in nominal gerunds. First, recall that within the sentential/verbal domain, *-ing* is a lowering affix in the sense of Chomsky (1957).

36. John was being quickly kicked when the police came.
 37. John was quickly kicking when the police came.

If we assume (as has long been assumed) that the adverb *quickly* marks the edge of the verbs movement, we can clearly see that *-ing* appears structurally higher and lower than the adverb. If we follow Chomsky's (1955) generalization about the structural relationship of affixes with the mechanisms of Bobaljik (1994), we get a system where virtually all English TAM morphology is PF-morphemes. Thus, the verb never raises to the head that houses *-ing*, but merger is able to occur through linear adjacency (which ignores the adjunct *quickly* in example 37).

What does this mean for nominal gerunds? If we assume some inherent connection between the different forms of *-ing* (perhaps ala Siddiqi (2010) who argues for a single lexical item *-ing*), then the notion that *-ing* does not require the root to head move into it is not that implausible. There are other reasons to assume that affixes like –

ing and affixes like *-(a)tion* are different types of morphemes. *-(a)tion* can trigger phonological changes in the stem while *-ing* cannot:

38. destroy: destroying ~ destruction

39. electrocute: electrocuting ~ electrocution

If the nominal gerund *-ing* is a “lowering”-affix then the explanation to why particles can appear in the construction (in contrast to derived nominals) is identical to the explanation to why incorporated particles can appear in the verbal domain. The verbal/nominal gerundizing morphology undergoes merger with the stem at PF, and thus the incorporated particle does not cause a Mirror Principle violations/morphological crash.

The result is the explanation for why 40 and 41 are morphologically licit is the same. In both cases the morpheme *-ing* is able to attach to the stem *look* without interference from the incorporated particle *up* because the merger happens post-syntactically, at PF and the fact that the particle and root/verb stem share a single head is no longer relevant.

40. John had been looking up the facts....

41. John’s looking up of the facts...

This analysis does require a very slight modification to the structure of nominal gerunds offered in chapter 2. There I suggest that the root moved into the n^0 in nominal gerunds (by analogy to derived nominals). Of course, that suggestion now appears to be incorrect. In nominal gerunds, the root does not move and morphological merger of the root and *-ing* occurs post-syntactically.

42. Revised Nominal Gerund Structure

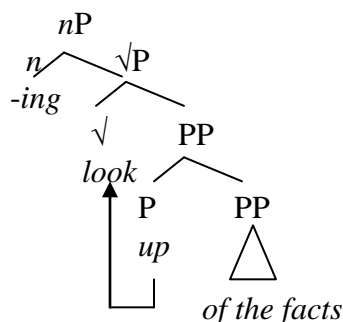

5.3.3 Non-Latinate Derived Nominals

Non-Latinate derived nominals pose a problem for the analysis I have developed in the previous sections. As a group, they also fail to allow particles and resultatives. The failure to allow particles is expected by either an event-based analysis or a morphology-based analysis. In an event analysis, particles represent complex events which are incompatible with the construction. In the morphological analysis, the particle still needs to incorporate with the root, but incorporating will result in a Mirror Principle violation because the root must raise into *n*. However, these two approaches do seem to make different predictions with respect to resultatives. In the event-based approach, resultatives are ruled out because the event-type is incongruous with the construction. In the morphological approach, there is no inherent ban on resultatives in derived nominal constructions. That is to say, there is nothing inherent about the structure which prevents resultatives from occurring (indeed, if Harley 2008 is correct and Latinate verbs are analogous to resultative and particle constructions an event-based analysis would have major problems with a majority of derived nominals). It appears there are no resultatives in derived nominals. However, what is critically lacking from the arguments for an

event-based approach is a predicate which allows resultatives in the verbal domain but fails to do so when derived as a nominal. That is to say, that all Anglo-Saxon predicate that can be derived nominals fail to allow resultatives in the verbal domain as well.

Derived Nominal Predicates Failure to Allow Resultatives

- 43. *John's marriage of Betty happy
- 44. John married Betty (*happy).
- 45. The bank shrank his assets (*tiny)
- 46. The bank's shrinkage of his assets (*tiny)

Critically, there is no evidence that derived nominals fail to allow event structure that the predicate would otherwise allow. Therefore, making the argument that the failure to allow resultatives is a property of the construction does not immediately follow. Now, it is conceivable that we could argue that the construction “selects” for predicates which do not allow resultatives. However, this is a very different style of argument.

Non-Latinate derived nominals are rare and somewhat idiosyncratic. If the construction were selecting for predicates of a certain type (in this case, those that cannot take resultatives) it might be reasonable to expect that all (or most of) predicates of that type could participate in the derived nominal construction. That is not the case. The number of non-Latinate verbs that can participate in derived nominal constructions is extremely small—thus it is hard to make any meaningful generalizations about it.

5.4 Conclusion

The apparent restrictions on events in derived nominals are not caused by any limitations in the event-structure of the construction. Rather, the apparent restriction is

due to a group of separate – but interacting – set of morpho-syntactic properties of the elements which comprise derived nominals and nominal gerunds.

Given that the bulk of derived nominals are derived from Latinate verb-forms, the absence of particles and resultatives generally is not surprising. Latinate forms are already bipartite in structure and (with limited exceptions) cannot allow particles or resultatives. Thus the absence of these forms in most derived nominals is readily explained. The exceptional Latinate forms that do allow particles (and the rare Anglo-Saxon forms which have derived nominal forms) can be explained by differences in the morphological properties of the derived nominal, which differ from the nominal gerund. Derived nominal suffixes require the stem to head move into its n^0 position, the nominal gerund nominalizer *-ing* has no such requirement and is a “lowering” affix which can undergo merger through linear adjacency at PF. If we assume that particles within nominals must incorporate into the root (which is an admittedly unexplained, but natural assumption given the adjacency requirement of particles found only in nominals), then the availability of these constructions falls out naturally from standard assumptions of morphological realization (i.e., that morphology and syntax match). Derived nominals cannot have particles because the incorporated particles block the nominalizing suffix from attaching to the root. Nominal gerunds avoid this problem because morphological merger of *-ing* is a PF operation based on linear order and the root is visible without the particle.

I argue that the reason why resultatives do not occur in Anglo-Saxon derived nominals is actually a consequence of which predicates appear in the construction and not

something inherent to the construction itself. Anglo-Saxon derived nominals are fairly rare and there do not appear to be any examples of Anglo-Saxon predicates which allow resultatives in the verbal domain that also disallow them in derived nominals.

The end result is that what appeared to be a limitation on event structure is actually an accident of morphology. This result is quite positive, because the event-based approach and Harley's (2008) analysis of Latinate verbs were at odds with each other. Under Harley's analysis, Latinate verbs are syntactically like particle constructions and derived nominals. As such, they should be banned from derived nominals in an event-based approach; instead, they form the core of construction.

The analysis offered here is not without its limitations. The mandatory incorporation of particles in nominals is seemingly inexplicable. Though, the motivation for particle incorporation is generally unexplained. The data does clearly suggest that incorporation is mandatory. Given this, perhaps a more salient question for an analysis of verbal particles is why incorporation is not mandatory there (especially given that it can happen).

Overall, the analysis presented here allows us to maintain a core assumption about the syntax-semantics interface: that syntactic complexity and semantic complexity are correlated. Given the findings in chapter 2, if nominal gerunds did allow more complex events, that assumption would be challenged. Since the apparent restrictions on events can be reduced to an accident of morphology, we are left with a theory that is still coherent.

CHAPTER 6: CONCLUSIONS

I do not wish to rehash the individual findings of each of the previous chapters in this one. Those results are already discussed extensively in the introductory chapter and in the relevant chapters themselves. Rather, I would like to focus on unifying those individual conclusions and avenues for future inquiry into these topics.

There are a number of distinct conclusions in this work, but all together they form a coherent unified conclusion: the projections from roots are limited to a certain size and often a particular order. In a sense, we could assume that the verbal projection is the most natural course for a root to grow. Roots will grow into verbs and then clauses, unless a nominalizer, adjectivizer, etc. enters the derivation. As we saw with nominalizers, this can happen at various points on the path to clause-hood. Nominal gerunds are roots that have been nominalized earliest in the derivation. Derived nominals are intermediate to that. Verbal gerunds contain the most verbal elements. A basic typology can be seen in figure 6-1, below.

Figure 6-1 Typology of Nominalization

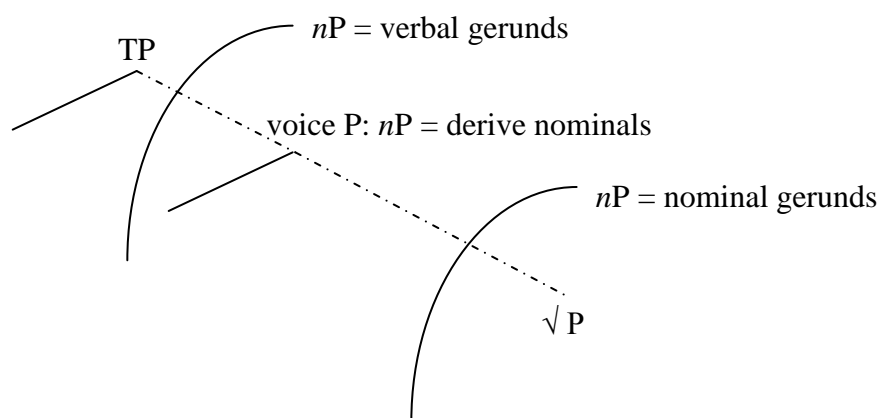

This figure shows the relevant points along the derivation from the root where the nominalizer is introduced. The nominal gerund nominalizer appears lowest appearing somewhere between the root and where voice would appear. The derived nominal nominalizer appears at a position equivalent to where voice appears in the verbal system. The verbal gerund nominalizer appears somewhere between voice but before tense.

In a sense, this is like the Parallelist Hypothesis that I argued against in the first chapter. But, in actuality it provides an alternative analysis. Overlaps between the verbal and nominal system are to be expected because there is verbal structure embedded in some nominal structures. But it is not true of all nominals. Non-argument taking nominals (see Grimshaw 1990) don't pattern with clauses in any real sense and this is exactly what is predicted in the style of analysis offered in this dissertation.

The typology I've outlined and the facts derived from that typology open up a number of interesting lines of inquiry which there was not time to pursue in this dissertation. I would like to address some of these to conclude the dissertation.

6.1 Notes for the Future

There are a number of questions that were most noticeable unaddressed in this dissertation. I would like to cast some light on the issues and sketch what I believe might be paths to take in addressing them. Many of these are subjects which I seek to address going forward.

6.1.1 Verbal Gerunds

The structure of verbal gerunds for instance was largely just assumed to be something like that offered in Baker (2005). However, there may be some considerable

insight to be drawn from a more in detailed look at verbal gerunds with specific references to the properties discussed here: especially the differences between derived nominals and nominal gerunds highlighted in chapter 2.

6.1.2 Aspect, Nominalization and Morphological Identity

There also appears to be a deep connection between some forms of nominalization (namely, gerunds) and aspect. The exact nature of this connection is still rather puzzling. Siddiqi (2010) attempts to provide a unified account of the gerund/aspect suffix *-ing* in English. I have little to add to this discussion at this time, other than to note that this pattern is not limited to English. Aspectual morphology and nominalizing morphology overlap in similar patterns in a number of disparate languages. In Scots Gaelic, the aspectual particle *ann* occurs with nominal predicates (Reed 2012). In Cherokee, there is a special deverbalizer in complementary distribution with aspect markers that occurs with some nominalized forms though true aspect is also possible (Stone 2010). Facts about aspect being embedded within nominalization have received fairly robust consideration (see: Croft 1991, Koptjevskaja-Tamm 1993, Embick 2000, Alexiadou 2001, Nordlinger and Sadler 2004). But discussion of morphological identity is still an area that deserves considerable attention.

The cross linguistic evidence suggests that there is a deeper connection between aspect and nominalization. The explanation could be synchronic like that of Siddiqi (2010) where there is a feature or features which unify aspectual marking and nominalization. I believe that the most likely explanation will be found in a mixed diachronic-synchronic approach like those of van Gelderen (see van Gelderen 2004,

among many other of her works). Such an explanation could capture the cross-linguistic generalizations without needing to stipulate that such connections are active synchronically. Key (2011) has already had positive results with such an approach with Turkish nominalization and causatives.

6.1.3 Regularity

The other major issue that I wish could've received more attention in this work is the role of syntactic operations on morphological regularity. In chapter 5, I offered a tentative analysis as to why gerunds surface completely regularly and derived nominals exhibit such idiosyncrasies. The explanation provided there was too tentative to be fully correct. However, I do believe that nominalizations provide the perfect petri dish for theories of regularity since there are multiple ways to produce nominalizations and these differing forms are on opposite ends of the regularity continuum.

REFERENCES

- Abney, Stephen. 1987. *The English noun phrase in its sentential aspect*. PhD Diss., MIT, Cambridge, MA.
- Ackerman, Farrell and Gert Webelhuth. 1998. *A Theory of Predicates*. CSLI Publications, Stanford
- Alexiadou, Artemis. 2001. *Functional Structure in Nominals: Nominalization and Ergativity*. John Benjamins.
- Baker, Mark. 1985. The Mirror Principle and Morpho-syntactic Explanation. *Linguistic Inquiry* 16.3: 375-415.
- Baker, Mark. 1988. *Incorporation: A Theory of Grammatical Function Changing*. The University of Chicago Press, Chicago.
- Baker, Mark. 2005. On Gerunds and the Theory of Categories. Ms, Rutgers University
- Barss, Andrew and Howard Lasnik. 1986. A note on anaphora and double objects. *Linguistic Inquiry* 17: 347-354.
- Basilico, David. 2008. Particle verbs and benefactive double objects in English: high and low attachments. *Natural Language and Linguistic Theory* 26: 731-773.
- Bobaljik, Jonathan. 1994. What does adjacency do? In *MIT Working Papers in Linguistics 22: The Morphology-Syntax Connection* by Heidi Harley and Colin Phillips (eds.) 1-32.
- Bobaljik, Jonathan and Höskuldur Thraínsson. 1998. Two heads aren't always better than one. *Syntax* 1: 37-71
- Booij, Geert. 1990. The boundary between morphology and syntax: separable complex verbs in Dutch. *Yearbook of Morphology* 3, 45-63.
- Borer, Hagit. 2005. *The Normal Course of Events: Structuring Sense vol II*. Oxford University Press, New York.
- Bresnan, Joan. 1982. The Passive in Lexical Theory . In Joan Bresnan (ed.), *The Mental Representation of Grammatical Relations*. The MIT Press, Cambridge.
- Carrier, J. and J. Randall. 1992. The argument structure of syntactic structure of resultatives. *Linguistic Inquiry* 23: 173-234.

- Chierchia, Gennaro. 1984. *Topics in the syntax and semantics of infinitives and gerunds*. PhD Diss., University of Massachusetts Amherst.
- Chomsky, Noam. 1957. *Syntactic Structures*. Mouton, The Hague
- Chomsky, Noam. 1970. Remarks on Nominalization. Jacob, A. & Rosenbaum, P. (eds.), *Readings in Transformational Grammar*. Ginn and co., Waltham, MA.
- Chomsky, Noam (1973) “Conditions on Transformations”. In Stephen R. Anderson and Paul Kiparsky, eds., *A Festschrift for Morris Halle*. Holt, Rinehart and Winston. , New York. (Reprinted in Noam Chomsky, ed. (1977) *Essays on Form and Interpretation*. pp. 81–160. New York: North-Holland)
- Chomsky, Noam. 1981. *Lectures on Government and Binding: The Pisa Lectures*. Foris Publications, Holland
- Chomsky, Noam. 1983. Some Conceptual Shifts in the Study of Language. In L. Cauman, I. Levi, C. Parsons and R. Schwartz (eds) *How Many Questions?: essays in honor of Sidney Morgenbesser*. Hackett, Indianapolis
- Chomsky, Noam. 1984. Knowledge of Language. MS. MIT.
- Chomsky, Noam. 1986. *Knowledge of Language; its nature, origin and use*. Praeger Paperback, USA.
- Chomsky, Noam. 1993. A minimalist program for linguistic theory. In K. Hale and S.J. Keyser (eds.), *The View from Building 20: Linguistic Essays in Honor of Sylvain Bromberger*, MIT Press, Cambridge. 1-52
- Chomsky, Noam. 1995a. *The minimalist program*. MIT Press, Cambridge
- Chomsky, Noam. 1995b. Bare Phrase Structure. In: G. Webelhuth, ed., *Government and Binding Theory and the Minimalist Program*, Blackwell, Oxford. 385-439
- Cinque, Guglielmo. 1994. On the evidence for partial N movement in the Romance DP. In *Paths toward universal grammar*, ed. Guglielmo Cinque, Jan Koster, Jean-Yves Pollock, Luigi Rizzi and Raffaella Zanuttini, 85–110. Georgetown University Press, Georgetown
- Cinque, Guglielmo. 1999. *Adverbs and functional heads: a cross-linguistic perspective*. Oxford University Press, New York

- Cinque, Guglielmo. 2002. *Functional Structure in DP and IP. The Cartography of syntactic structures, volume I*. Oxford University Press, New York
- Cinque, G Guglielmo. 2007. *The syntax of adjectives. A comparative study*. MS. University of Venice.
- Cinque, Guglielmo and Luigi Rizzi. 2010. *Mapping spatial PPs. The cartography of syntactic structures, vol. 6*. Oxford University Press, New York
- Croft, William. 1991. *Syntactic categories and grammatical relations: The cognitive organization of information*. University of Chicago Press, Chicago
- Dehé, Nicole. 2002. *Particle Verbs in English: Syntax, information structure, and intonation*. John Benjamins, Amsterdam.
- den Dikken, Marcel. 1995. *Particles: On the syntax of the verb-particle, triadic and causative constructions*. Oxford University Press: New York.
- Embick, David. 2000. Features, syntax, and categories in the Latin perfect. *Linguistic Inquiry* 31:185-230.
- Emonds, Joe. 1976. *A transformational approach to English syntax*. Academic Press, New York.
- Felix, Sascha. 1988. The structure of functional categories. *Groninger Arbeiten zur germanistischen Linguistik* 29
- Fraser, Bruce. 1965. *An examination of the verb-particle construction in English*. PhD Diss., MIT, Cambridge, MA.
- Fraser, Bruce. 1970. Some remarks on the action nominalization in English. In R. Jacobs and P. Rosenbaum (eds.) *Readings in English transformational grammar*. Ginn, Waltham: 83- 98
- Fraser, Bruce. 1976. *The verb-particle combination in English*. Academic Press, New York.
- Fukui, Naoki, and Margaret Speas. 1986. Specifiers and projection. In Naoki Fukui, Tova R. Rapoport, and Elizabeth Sagey (eds.) *MIT working papers in linguistics* 8. Department of Linguistics and Philosophy, MIT, Cambridge: 128-172
- Giorgi, A. and F. Pianesi. 1997. *Tense and aspect: from semantics to morpho-syntax*. Oxford University Press, New York
- Grimshaw, J. 1990. *Argument Structure*. MIT Press: Cambridge, MA.

- Halle, Morris. 1997. Distributed Morphology: Impoverishment and Fission. *MIT Working Papers in Linguistics* 30, 425–449.
- Halle, Morris. and Alec Marantz. 1993. Distributed Morphology and Pieces of Inflection. In K. Hale and S.J. Keyser (eds.), *The View from Building 20: Linguistic Essays in Honor of Sylvain Bromberger*. MIT Press, Cambridge. 111-176
- Hamm, Fritz. 1999. Modelltheoretische Untersuchungen zur Semantik von Nominalisierungen. Habilitationsschrift, Tübingen: Seminar für Sprachwissenschaft der Universität Tübingen.
- Harley, Heidi. 2002. Possession and the double object construction. *Yearbook of Linguistic Variation* 2: 29-68
- Harley, Heidi. 2005. How do verbs get their names? Denominal verbs, Manner Incorporation and the ontology of verb roots in English. In Nomi Erteschik-Shir and Tova Rapoport (eds.) *The Syntax of Aspect*. Oxford University Press, Oxford: 42-64
- Harley, Heidi. 2008. The bipartite structure of verbs cross-linguistically, or Why Mary can't exhibit John her paintings. MS. University of Arizona
- Harley, Heidi. and Rolf Noyer. 1998. Mixed nominalizations, object shift and short verb movement in English. In *Proceedings of NELS 28*, University of Massachusetts at Amherst: GLSA
- Harley, Heidi and Rolf Noyer. 1999. State-of-the-Article: Distributed Morphology. *Glott International* 4.4: 3-9
- Harley, Heidi. and Elizabeth Ritter. 2002. Person and number in pronouns: a feature-geometric analysis. *Language* 78-3: 482-526.
- Hiraiwa, K. 2005. Dimensions of symmetry in syntax : agreement and clausal architecture. PhD Diss., MIT, Cambridge, MA.
- Horn, G. M. 1975 On the Nonsentential Nature of the POSS-ing Construction," *Linguistic Analysis* 1: 333-388.
- Hornstein, Norbert. 2000. *Move! A Minimalist Theory of Construal*. Blackwell, Oxford
- Ishikawa, Kazuhisa. 1999. English verb-particle constructions and a V⁰-internal structure. *English Linguistics* 16: 329-352.

- Ishikawa Kazuhisa. 2000. A local relation between particles and verbal prefixes in English. *English Linguistics* 17: 249-275
- Jackendoff, Ray 1973. The base rules for prepositional phrases. In Stephen R. Anderson and Paul Kiparsky (eds.), *Festschrift for Morris Halle*. Holt, Rinehart and Winston, New York: 345-356.
- Jackendoff, Ray. 1977. *X-bar syntax*. MIT Press, Cambridge
- Jackendoff, Ray. 1997. *The Architecture of the Language Faculty*. MIT Press, Cambridge.
- Johnson, Kyle. 1991. Object positions. *Natural Language and Linguistic Theory* 9: 577-636.
- Katz, Graham E. 1999. Anti neo-Davidsonianism: against a Davidsonian semantics for state sentences. Ms., University of Tübingen.
- Kayne, Richard. 1985. Principles of particle constructions. In *Grammatical Representation*. By Jacqueline Guéron, Hans-Georg Obenauer & Jean-Yves Pollock (eds.). Foris, Dordrecht: 101-140.
- Kennedy, Arthur. 1920. The modern English verb-adverb combination. *Language and Literature*. Stanford University Publication, Stanford, CA. Vol 1-1.
- Key, Greg. 2011. Event size and (the absence of) iterativity in Turkish causatives. Ms., University of Arizona
- Koizumi, Masatoshi. 1993. Object agreement phrases and the split VP hypothesis. In Jonathan David Bobaljik & Colin Phillips (eds.) *Papers on case and agreement I: MIT Working Papers in Linguistics* 18: 99-148.
- Koopman, Hilda. 1995. On Verbs That Fail to Undergo V-Second. *Linguistic Inquiry* 26, 139-163.
- Koptjevskaja-Tamm, Maria. 1993. *Nominalizations*. Routledge, London
- Kratzer, Angelika. 1996. Severing the External Argument from its Verb. In, J. Rooryck and L. Zaring (eds.) *Phrase Structure and the Lexicon*. Kluwer, Dordrecht: 109-137.
- Larson, Richard. 1988. On the double object construction. *Linguistic Inquiry* 19: 335-391.

- Lasnik, Howard. and M. Saito. 1984. On the nature of proper government. *Linguistic Inquiry*. 15: 235-289
- Lebeaux, David. 2009. *Where does Binding Theory Apply?* MIT Press, Cambridge.
- Levin, Beth and T.R. Rapoport. 1988. Lexical Subordination. *Proceedings of the 24th Annual Meeting of the Chicago Linguistic Society*: 275-289.
- Levin, Beth. and Malka Rappaport Hovav. 1996. Lexical Semantics and Syntactic Structure. In S. Lappin, (ed.) *The Handbook of Contemporary Semantic Theory*, Blackwell, Oxford: 487-507.
- Marantz, Alec. 1984. *On the Nature of Grammatical Relations*. MIT Press, Cambridge.
- Marantz, A. 1997. No escape from syntax: Don't try a morphological analysis in the privacy of your own lexicon? In A. Dimitriadis, L. Siegel, et. al., (eds.). *University of Pennsylvania Working Papers in Linguistics*, vol. 4.2, *Proceedings of the 21st Annual Penn Linguistics Colloquium*: 201-225.
- Masini, Francesca. 2005. Multi-word expressions between syntax and the lexicon: the case of Italian verb-particle constructions. *Sky Journal of Linguistics*. 18: 145-173.
- Nordlinger, Rachel, and Louisa Sadler. 2004. Nominal tense in crosslinguistic perspective. *Language* 80:776-806.
- Noyer, Rolf. 1992. *Features, positions and affixes in autonomous morphological structure*. PhD Diss., MIT, Cambridge, MA.
- Ogawa, Yoshiki. 2001. *A Unified Theory of Verbal and Nominal Projections*. Oxford University Press, Oxford.
- Parsons, Terence. 1990. *Events in the Semantics of English*. MIT Press, Cambridge.
- Pesetsky, David. 1987. Wh-in-situ: Movement and unselective binding. In Eric Reuland and Alice ter Meulen (eds.) *The representation of (in)definiteness*. MIT Press, Cambridge: 98-129
- Postal, Paul. 1974. *On Raising: One Rule of English Grammar and Its Theoretical Implications*. MIT Press, Cambridge
- Radford, Andrew. 2004. *English Syntax: An Introduction*. Cambridge University Press, Cambridge.

- Ramchand, Gillian. 2007. Events in Syntax: Modification and Predication. *Language and Linguistic Compass* 1-5: 476-497
- Ramchand, Gillian. and Peter Svenonius. 2002. The Lexical Syntax and Lexical Semantics of the Verb-Particle Construction. Proceedings of WCCFL 2002.
- Reed, Sylvia. 2012. *A revised semantics of grammatical aspect: evidence from Scottish Gaelic*. PhD Diss., University of Arizona, Tucson AZ
- Ritter, Elizabeth and M. Wiltschko. 2009. Varities of INFL: Tense, Location and Person. In Jeroen van Craenenbroeck (ed.) *Alternatives to Cartography*. Mouton de Gruyter, New York: 153-202
- Rizzi, Luigi. 1996. Residual Verb Second and the Wh-criterion. In: Adriana Belletti and Luigi Rizzi (eds.), *Parameters and functional heads*, 63-90. Oxford University Press, New York
- Roeper, Thomas. 2005.: Chomsky's *Remarks* and the transformationalist hypothesis. In Pavol Štekauer and Rochelle Lieber, (eds.) *Handbook of Word-Formation*. Springer, Dordrecht. 125-46.
- Ross, John. 1967. *Constraints on variables in syntax*. PhD Diss., MIT, Cambridge, MA.
- Sichel, Ivy. 2010. Event Structure Constraints in Nominalization. In *The Syntax of Nominalizations across Languages and Frameworks. Interface Explorations 23*. Mouton de Gruyter, Berlin. 151-190
- Siddiqi, Daniel. 2010. *On Affix Lowering and the Participial Form*. Ms., Carleton University.
- Simpson, J. 1983. Resultatives. In L. Levin, M.Rappaport and A. Zaenen (eds.). *Papers in Lexical Functional Grammar*. Indiana University Linguistics Club, Bloomington.
- Speas, Peggy. 1990. *Phrase Structure in Natural Language*. Kluwer Academic Publishers, Dordrecht.
- Sproat, R. 1985. *On Deriving the Lexicon*. PhD Diss., MIT, Cambridge, MA.
- Starke, Michal. 2011. Towards an elegant solution to language variation: Variation reduces to the size of lexically stored trees. MS. Barcelona, Spain

- Stiebels, Barbara and Dieter Wunderlich. 1994. "Morphology feeds syntax: The case of particle verbs". *Linguistics* 32: 913-968.
- Stone, Megan. 2010. Nominalizations without Tense: Evidence from Cherokee. Ms., University of Arizona
- Stowell, Tim. 1981. *Origins of Phrase Structure*. PhD Diss., MIT, Cambridge, Mass.
- Svenonius, Peter. 1992. Movement of P⁰ in the English verb-particle construction. In *Syntax at Santa Cruz* by H. Andrew Black and James McCloskey (eds.) 1: 93-113.
- Szabolcsi, Anna. 1989. Noun Phrases and Clauses: is DP analogous to IP or to CP? In J. Payne (ed) *The Structure of Noun-Phrases*. Mouton, Amsterdam.
- Szabolcsi, Anna. 1991. The Noun Phrase. Ms. UCLA.
- Thráinsson, Höskuldur. 1996. On the (non-) universality of functional categories. In: Werner Abraham, Sameul David Epstein, Höskuldur Thráinsson and Jan-Wouter Zwart (eds.), *Minimal ideas: syntactic studies in the Minimalist framework*. John Benjamins, Amsterdam: 252-281.
- Travis, Lisa. 1984. *Parameters and Effects of Word Order Variation*. PhD Diss., MIT, Cambridge, MA.
- Lisa Travis and G. Lamontagne, 1987. The syntax of adjacency. In: M. Crowhurst (ed), *Proceedings of the Sixth West Coast Conference on Formal Linguistics*. CSLI Publications: Stanford, CA. 173–186.
- van Craenenbroeck, Jeroen. 2009. Alternatives to cartography: an introduction. In: Jeroen van Craenenbroeck (ed.) *Alternatives to Cartography*. New York: Mouton de Gruyter. 1-14.
- Van Gelderen, Elly. 2004. *Grammaticalization as economy*. John Benjamins, Amsterdam
- van Riemsdijk, Henk. 1978. *A Case Study in Syntactic Markedness*. Foris, Dordrecht.
- Wasow, Thomas and Tom Roeper. 1972. On the subject of gerunds. *Foundations of Language* 8: 44-61

- Wechsler, Stephen. 2005. Resultatives under the “event-argument homomorphism” model of telicity. In Nomi Erteschik-Shir and Tova Rapoport (eds.) *The Syntax of Aspect: Deriving Thematic and Aspectual Interpretation*. Oxford University Press: 255-273
- Whorf, Benjamin. 1956. *Language thought and reality*. MIT Press, Cambridge
- Wiese, Richard. 1996. *The phonology of German*. Clarendon Press, Oxford.
- Williams, Edwin. 1987. Implicitly arguments, the binding theory, and control. *Natural Language & Linguistic Theory* 5-2: 151-180
- Wurmbrand, Susi. 2000. The structure(s) of particle verbs. Ms., McGill University.
- Zeller, Jochen. 1997. Against Overt Particle Incorporation. *UPenn Working Papers in Linguistics* 4.2: 291-307.
- Zwart, C. Jan-Wouter. 1997. *Morpho-syntax of verb movement*. Kluwer, Dordrecht.
- Zucchi, Alessandro. 1993. *The Language of Proposition and Events*. Kluwer, Dordrecht.