

# **THE DESIGN AND DEVELOPMENT OF THE PROTOTYPE ENHANCED FLIGHT TERMINATION SYSTEM**

**Jeff S. Vetter, BSEET  
Travis Cribbet, BSEET(Student)  
CMC Electronics Cincinnati  
Mason, OH 45040**

## **ABSTRACT**

Range Safety Systems are used for destruction of a vehicle should a malfunction cause the vehicle to veer off course. All vehicles launched into space require implementation of a Range Safety System. For years the IRIG receivers have been used with relatively good success. Unfortunately, the IRIG receivers do not provide a high level of security. High alphabet receivers were later developed for use on the big launchers (Atlas, Delta, Titan, etc) and the manned missions (Shuttle) to provide added security. With the IRIG based system, several problems have occurred resulting in the loss millions of dollars worth of equipment. Due to the problems that have occurred it has become apparent that there is a need for a more secure, low cost, type of range safety receiver.

This paper describes the design and development of the prototype EFTS system. Mission critical parameters are discussed including selection of the encryption and forward error correction algorithms. Actual measured performance including message error rate characteristic is presented.

## **KEY WORDS**

Flight Termination, Range Safety, EFTS, FTR, Encryption, Reed-Solomon, FPGA.

## **INTRODUCTION**

The Encoder and Receiver described in this paper were designed to meet the requirements for the prototype EFTS system, issued under contract to CMC Electronics Cincinnati (CMCEC) from Edwards Air Force Base. The Encoder unit will be integrated with the existing ground-to-air data link transmitting stations and operate in conjunction with the flight termination receiver unit. The modulation format of the EFTS waveform is Continuous Phase/ Frequency Shift Keying (CPFSK), also known as Pulse Code Modulation/Frequency Modulation (PCM/FM), operating at a 7.2 kbps coded bit rate. A block diagram of the Enhanced Flight Termination System (EFTS) is shown in Figure 1.

The Encoder is implemented with a laptop computer executing Windows based software and a 19 inch rack mount unit. The Windows software allows user entry of commands and outputs a serial command to the rack mount unit for message formatting and precise message timing. The output of the Encoder rack mount unit is baseband audio suitable for direct connection to a variety of FM transmitters.

The Receiver is implemented reusing an existing, field-proven RF design and a new digital decoder design. The CR-122 RF section was chosen for reuse as the RF portion of the EFTS due to its small size and industrial grade parts program. The RF assembly receives a 428 MHz UHF carrier and delivers demodulated audio to the decoder assembly. An FPGA based DSP processor samples the audio and performs all the message processing necessary to decode and output the received message.

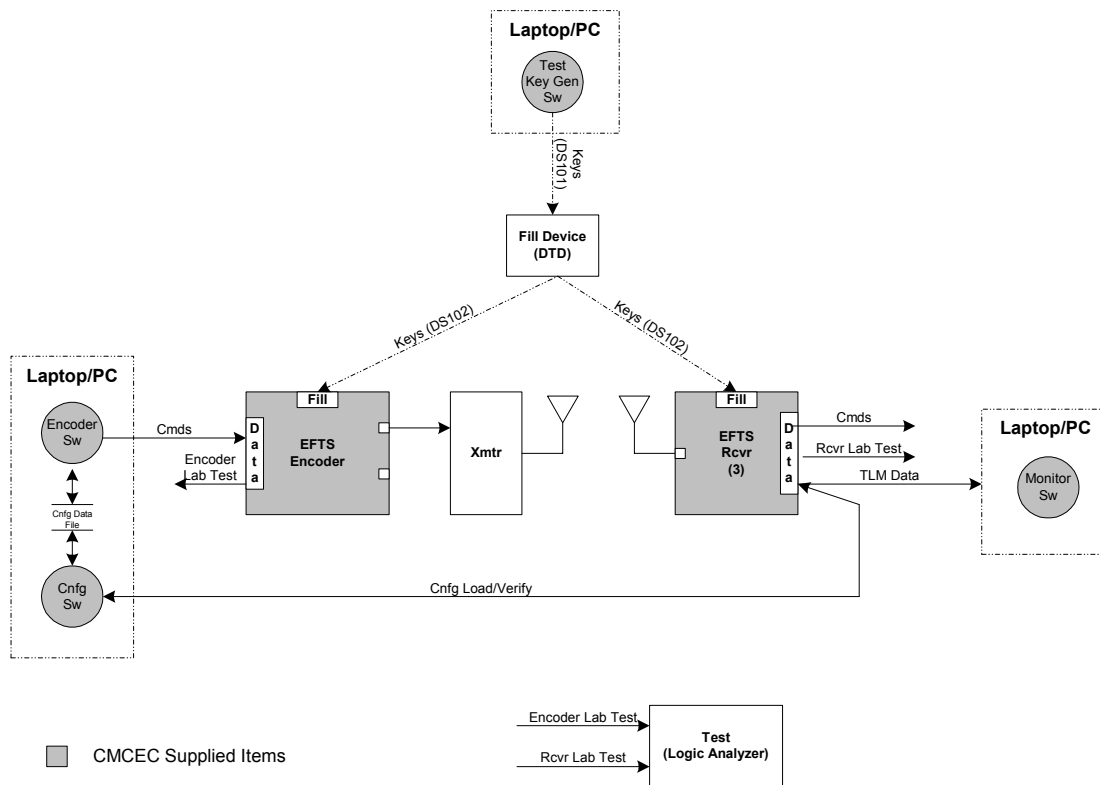
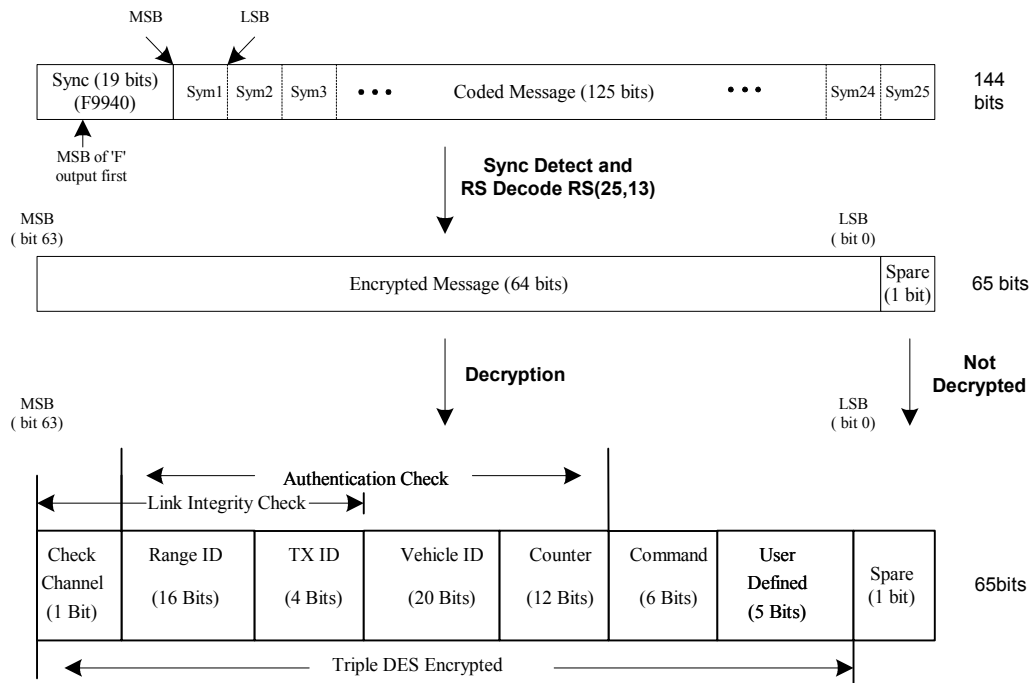

**Figure 1.** EFTS System-level Block Diagram

### EFTS MESSAGE FORMAT

The EFTS message format is shown in Figure 2. The encrypted and coded EFTS messages are 144 bits in length and are sent continuously at a 50Hz rate. The content of the message does not change unless the user initiates another command. A 19-bit Barker code frame sync is located at the start of the coded message to permit detection of the “start of block” through the use of a correlator. The location of the start of the coded data is required due to the use of block based FEC encoding, which

requires determination of the exact location of bit one of the block for proper decoding<sup>1</sup>. In this case, Reed Soloman encoding was selected because of its *maximum distance* property, allowing for selection of a shorter code, and due to its common use and availability thus promoting multi-vendor implementations (additional discussion of the code selection is provided below under “EPLRS Compatibility”). Following Reed-Solomon decoding, the resulting encrypted message is reduced to 65 bits since the parity bits are removed. After Triple-DES decryption, the resulting 65-bit message is parsed into the fields shown in Figure 2 and processed as discussed below.



**Figure 2. EFTS Message Format**

A brief description of the EFTS message fields is provided in Table 1 and the commands in Table 2.

**Table 1. EFTS Message Fields**

Field	Description
Check Channel	Used to test FTR’s ability to receive a command. Note, can test all FTR’s links without having to uniquely address each unit.
Range ID	Uniquely addresses each Range. Multi-range

<sup>1</sup> An alternate form of locating the start of block is being investigated. This method eliminates the requirement for a frame sync, because here the receiver would attempt a decode/decrypt/command authentication each and every bit. If the message passed all these checks, then it is deemed a valid message. The probability of an inadvertent message being authenticated is at an acceptably low risk. This approach is only possible since the processing time of the receiver is less than one bit (<139us).

	missions will be assigned common Range-ID
TX ID	Uniquely addresses up to 16 transmitters on each Range
Vehicle ID	Uniquely addresses each Vehicle
Counter	Authentication counter, must be equal to or greater than counter stored in receiver for command to be processed
Command	See Table 2 below
User Defined	General-purpose digital control lines. May be used to control rudders, engine speed, etc.
Spare	General purpose digital control line (unencrypted)

**Table 2. EFTS Commands**

<b>Field</b>	<b>Description</b>
Default	Resets all other outputs
Optional	Sets Optional output
Arm	Sets Arm output
Terminate	Sets Terminate output, must have received Arm first
Test	Sets Test output, no specific tests performed in this prototype unit. Receiver contains several online tests
Disable	Disables reception capabilities of the receiver. Power remains on
Command Counter Clear	Sets the command counter to 0
Wireless Enable	Readys the receiver to change configurations. User Defined field contains new configuration number.
Wireless Commit	Actually changes receiver to new configuration. Must receive the Wireless enable first. Benefit is that configuration can be changed without physical connections, i.e., receiver remotely located in missile.

## **EFTS ENCODER**

The primary function of the Encoder is to generate properly formatted EFTS messages from user-supplied data for transmission via existing range UHF transmitters. A top-level block diagram of the Encoder is shown in Figure 3. The PC Controller is implemented using a laptop<sup>2</sup> executing Labview GUI software and performs the following functions:

- Provides the Graphical User Interface (GUI), which allows the user to control the bits in the EFTS Frame.

---

<sup>2</sup> Laptops executing Labview may not be an acceptable solution for real flight missions, but is a good choice for this prototype effort due to the flexibility and ease of modification.

- Formats the data into the EFTS packet, which is sent to the Coder Unit.
- Outputs to the Coder Unit only when a new message is generated.
- Displays status information from the Coder Unit.

The Coder is a 19” rackmount unit implemented using the same digital decoder card developed for the receiver but executing a different VHDL program. The functions of the Coder are as follows:

- Performs the Triple Data Encryption Standard (3DES) encryption as well as Reed-Solomon (RS) encoding.
- The 64 bits from the 3DES, plus the Unencrypted Spare bit, are encoded to 125 bits by the RS(25,13) encoding.
- A 19-bit Barker Code is added to the resulting 125-bit stream to provide a 144-bit packet.
- Responsible for continuously outputting messages.

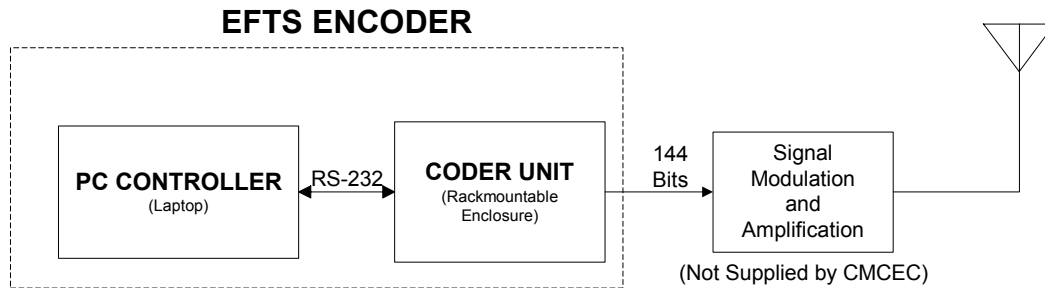

**Figure 3.** EFTS Encoder System-level Block Diagram

As shown in Figure 4, the GUI is setup to control three vehicles at a time. Three were chosen since only three prototype receivers were produced for this prototype phase. Encoder requirements for the next phase will likely require control of more vehicles. Vehicles 2 and 3 are shaded since they were disabled when the GUI image was captured. When enabled, the Encoder outputs commands to each vehicle in a round robin fashion. The GUI allows the user to enter a Range ID, Vehicle ID, and Transmitter ID, which uniquely address a vehicle. Clicking on a command causes a serial message to be output to the coder unit where it is TDES encrypted, Reed-Solomon encoded and inserted into the frame output buffer. The GUI automatically increments the command counter each time a command is sent. Controls are provided for test purposes to reset the command counter in the Encoder only. Other controls are provided to set the consecutive number of times a command is output after a command is initiated by the user (ICQ) and the number of commands output to each vehicle before proceeding to the next (CRQ).

Reference Figure 5 for a picture of the Encoder Rackmount front panel. Connectors are provided to allow connection to a DS-102 type fill device, such as the DTD, and a data connector to monitor commands currently output by encoder. A data insertion port is provided for test purposes to allow insertion of a master clock, which introduces timing error on the biphase outputs, or to directly drive the biphase outputs through the internal 4-pole shaping filters.

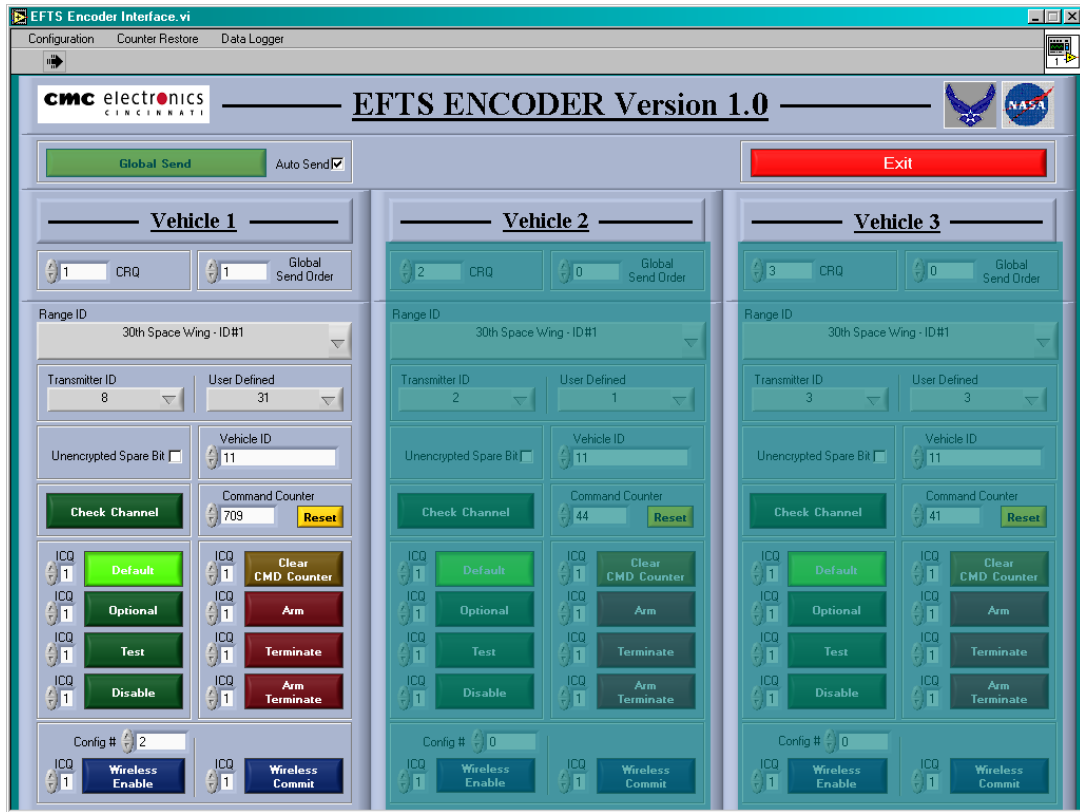

**Figure 4.** EFTS Encoder GUI

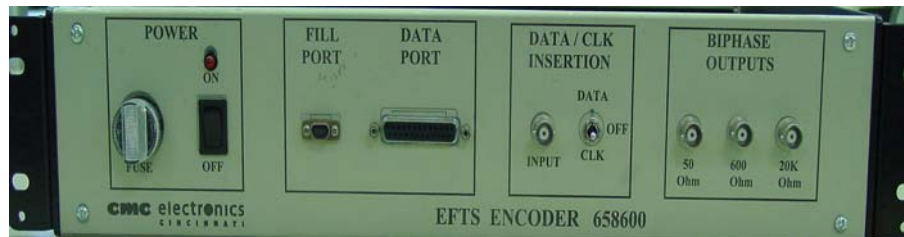

**Figure 5.** EFTS Encoder Rackmount Unit

## EFTS RECEIVER

The EFTS Receiver is a UHF band receiver operating at 428 MHz capable of receiving the CPFSK digitally formatted EFTS message discussed above. 428 MHz was a convenient frequency for this phase and is not a requirement for the EFTS system. Any frequencies (420-450MHz) currently being used for FTRs will also be acceptable for the follow on EFTS phases. A few features of the Receiver are as follows:

- UHF Band Receiver (428 MHz)
- Front end RF section is a field proven CR-122

- Performs Message Based Processing per EFTS specifications
- 50 Hz Message Rate
- -107 dBm Guaranteed Sensitivity (1E-4 MER), -116 dBm Threshold
- Immune to ELPRS Burst
- Utilizes Reed Solomon Decoding
- Utilizes 3DES Encryption, DS-102 compatible
- All Commands Output as TLM Level Data
- 1 Pound (0.45 Kilograms)
- 27 in<sup>3</sup> Volume
- 2.4 Watts Power Dissipation
- Parts are Commercial COTS, Industrial Grade Plastic

The Receiver Interfaces are shown in Figure 6 and consist of an RF Input, 28 VDC power, fill, and telemetry output. Note no high current outputs were required or provided for this phase.

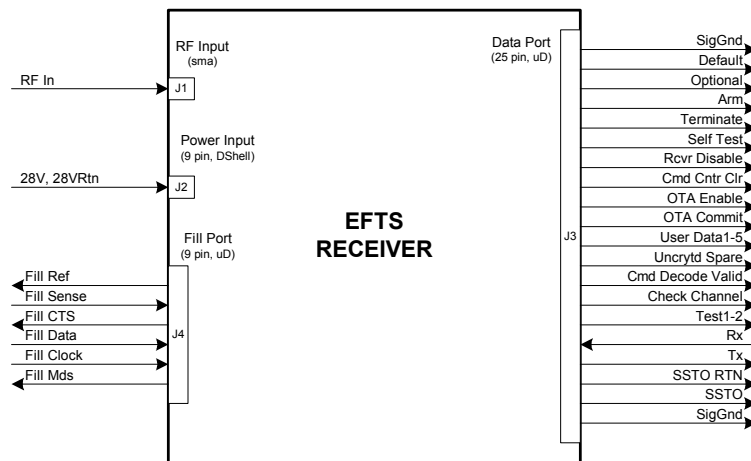

**Figure 6. EFTS Coder Unit**

The Receiver is divided into three assemblies: RF/IF, Demod/PowerSupply, and Decoder. The RF/IF and Demod/PowerSupply assemblies were essentially reused from other products so will just be mentioned briefly here. A few features of the RF/IF are as follows:

- Single conversion receiver with 21.4 MHz IF
- Quadrature demodulator for CPFASK demodulation
- Predetection RF signal gain 166 dB with 90 dB AGC range
- Noise Figure approximately 5.0 dB

A block diagram of the decoder is shown in Figure 7. The decoder receives demodulated data from the Demod assembly, performs the necessary EFTS message processing and outputs the appropriate TLM command.

A 4-pole Bessel was used for the anti-aliasing filter. Four poles provide sufficient attenuation at the sample rate to prevent any significant aliasing. Only 5 out of the 12 bits from the serial A/D

converter are used. At this low sample rate, a 12 bit converter didn't add to the cost yet provided a very small package size. All of the digital processing functions are performed in an FPGA. Figure 8 shows the Windows software status display used to monitor receiver performance via the serial RS-232 port.

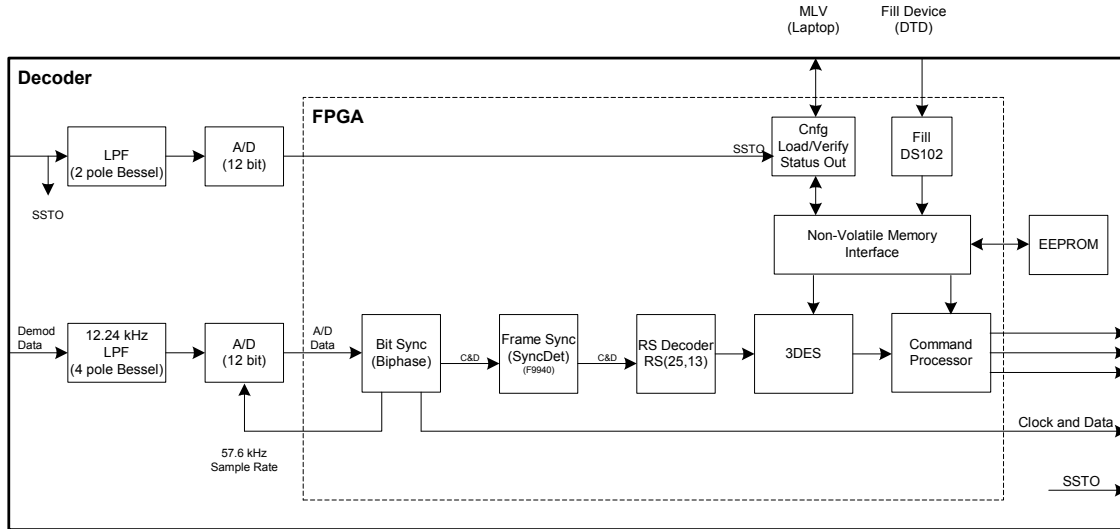

**Figure 7. EFTS Decoder Functional Block Diagram**

### EPLRS Compatibility

One of the key requirements levied on the EFTS receiver was to make it interoperate in the presence of Enhanced Position Location Reporting System (EPLRS) equipment. The EPLRS is a synchronous Time Division Multiple Access (TDMA) system that can generate up to ~1ms bursts of RF energy on the same carrier frequency as EFTS. The EFTS requirement is to operate normally with up to two of these pulses within each 20ms message frame. The RS(25,13) code was selected to meet this requirement. It corrects up to six, five bit symbols or 6 to 30 bits (depending whether there is one bit error per symbol or five bit errors per symbol). Since each pulse can straddle a codeword, one extra symbol per 1ms burst is required.

### MEASURED PERFORMANCE

The EFTS architecture described in this paper has been constructed as engineering units and several deliverable units. ATPs were performed and performance measurements have been taken. Figure 9 shows the MER error rate performance of the EDU and production units.

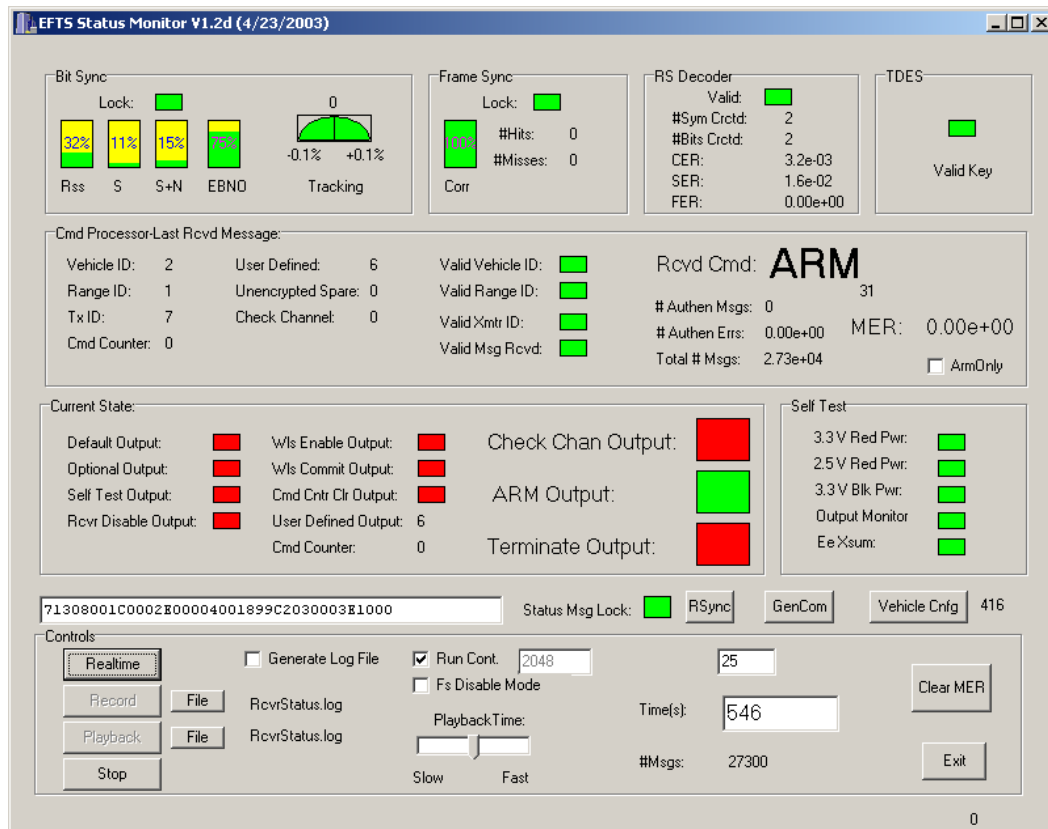

Figure 8. EFTS Status Monitor Display

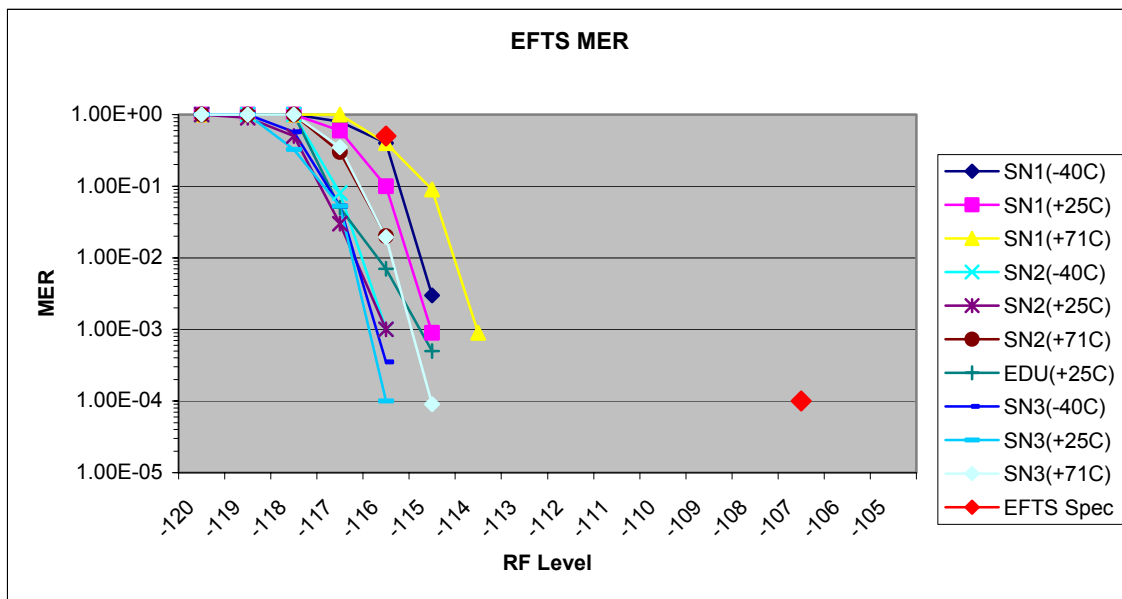

Figure 9. EFTS MER for Production and Engineering Units

## CONCLUSIONS

This paper presented information regarding the prototype Enhanced Flight Termination System. The key components being the Encoder and Decoder unit have been presented in detail. The document outlines the digital message format used in the system and the fundamental analog parameters used in the working prototype EFTS. The prototype EFTS Encoder and Receivers have been delivered to Edwards Air Force Base. During the summer of 2003 the customer will perform a battery of tests to measure the effectiveness of the new system. This includes mounting the unit within an F-15 in an effort to simulate the harsh conditions Flight Termination Systems must operate under. Testing of the prototype EFTS will confirm accidents, such as the inadvertent destruction of the Global Hawk aircraft that occurred on March 20, 1999, are prevented. The loss of this aircraft highlighted the need for a more secure, low cost type of range safety receiver, such as the EFTS.

## ACKNOWLEDGEMENTS

The authors would like to acknowledge the support of CMC Electronics Cincinnati for the writing of this paper and thank the following individuals for their comments and suggestions: Mark Dapore, Bruce Maples and the EFTS Team (specifically Robert Sakahara, Dennis Acre, and Tom McAndrews). We would also like to thank Dr Michael Rice of BYU for his contributions to the program.

## REFERENCES

[1] Wicker, Stephen B., Error Control Systems for Digital Communication and Storage, Prentice-Hall Inc., Upper Saddle River, NJ, 1995.

[2] Clark, George C Jr., and J. Bibb Cain. Error-Correction Coding for Digital Communications, Plenum Press, New York, NY, 1981

[3] Proakis, John G., Digital Signal Processing in Communication Systems, Van Nostrand Reinhold, Norwell, Mass., 1994.

[4] Sklar, Bernard, Digital Communications: Fundamentals and Applications, Prentice-Hall, Inc., Englewood Cliffs, NJ, 1988.

[5] harris, fred, "Digital Signal Processing as Applied to Communication Systems", Course Notes, Dec. 2000.