

FREQUENCY CALIBRATION FOR THE TRANSMISSION SYSTEM OF QUARTZ CRYSTAL MEASUREMENT USING GPS

Yang Jun, Zhang Qishan, Wu Jinpei

School of Electronic Engineering, Beihang University, Beijing, P. R.China, 100083

ABSTRACT

Quartz crystal is an important electronic element in the field of communication systems, computer systems, etc. It is important to precisely measure the frequency of quartz crystal unit for manufacturing. The Pi-network transmission system recommended by International Electrotechnical Commission (IEC) is generally acknowledged as a measurement technique. However it needs a precise frequency source. The frequency source must be calibrated within a regular period in the process of manufacturing. Frequency counters, time interval counters, phase comparisons, which are the most common frequency calibrations, are introduced in the paper. Nowadays GPS has also become the primary system for frequency calibration. GPS receivers provide 1 PPS (Pulse Per Second) with accuracy < 100 nanoseconds to UTC under normal conditions. Motorola UT Oncore timing GPS with time accuracy < 50 ns (1 sigma) uses time RAIM algorithm to ensure the validity and reliability of measurements. The comparison between the precise 1PPS and local reference is implemented. And the phase differences are logged and read by computer. According to the values, the frequency output of DDS is coordinated. In order to reduce the phase ambiguity, local reference is divided before comparison. The calibration can be implemented at any time by GPS. Block diagrams of calibration are presented in this paper.

KEYWORDS

GPS (global positioning system), Calibration, PI Network

INTRODUCTION

Quartz crystal is widely used in the field of communication systems, computer systems, etc. Quartz crystal has Piezoelectricity, which can convert mechanical energy into electric energy and vice versa. Energy losses of the conversion become the least at the appropriate frequency. Quartz crystal has much higher quality (Q) than other circuits, so it has high frequency stability. In general-purpose Quartz crystal, the Q values are generally in the range of 10^4 to 10^6 . It is important to precisely measure the frequency of quartz crystal unit for manufacturing. Pi-network transmission system

recommended by International Electrotechnical Commission (IEC) is generally acknowledged as a measurement technique for quartz crystal up to 200MHz. According to IEC-444, the PCI-based transmission system is designed as follow figure 1. Figure 1 shows the arrangement of the measurement jig with other circuits of a frequency generator, a local oscillator, a power divider, an attenuator, mixers, a phase difference measurement, a frequency calibration, a GPS receiver, and an A/D converter. To minimize the measurement error and phase ambiguity, frequencies of measurements are reduced to IF 450KHz by mixers. The determination of quartz crystal parameters is based on the measurement of complex impedance ^[1]. While quartz crystal is inserted in the pi-network jig, the signal from frequency generator is split into two paths by the power divider. One path's signal is directly mixed with the local oscillator to form an IF signal, the other path's signal is done like that through pi-network. Thus the phase difference and amplitudes of two paths' IF signals can be measured separately by the built-in phase meter and the A/D converter. After obtaining the data from measurements, parameters of an quartz crystal can be calculated. The measurement precision and error also depend on the frequency generator besides arrangement of pi-network, the accuracy of voltages and phase measurements. Accordingly the measurement method needs a precise frequency source. Moreover, the frequency source must be calibrated within the regular period in the process of manufacturing. Generally the standard frequency source is stored in the special place and kept by certain person. Thus the interval time between two calibrations is longer and the process of calibration is not convenient. How to frequently and conveniently calibrate the signal source?

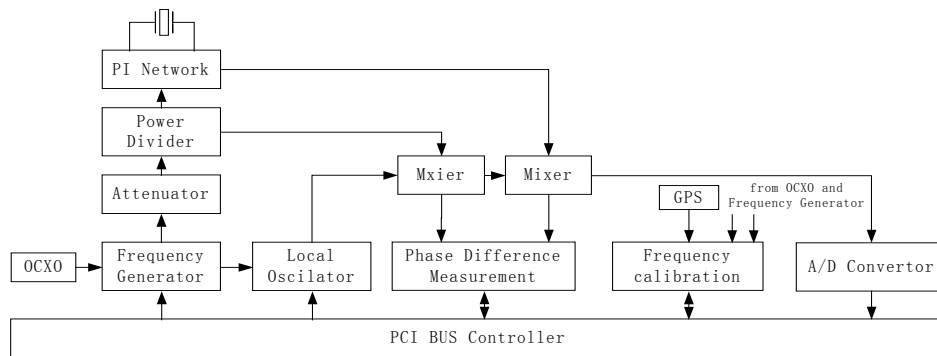

Figure 1 Block diagram of the transmission system

GPS satellites are controlled and operated by the United States Department of Defense (USDOD). The constellation includes at least 24 satellites (21 primary satellites and 3 in-orbit spares) that orbit the earth in six fixed planes inclined 55° from equator. Typically six satellites or more are in line-of-sight view all the time. GPS signals reception must be line-of-sight, which means that the antenna must have a clear view without blockages due to buildings, towers, etc. If a clear sky view is available. The signals can be received anywhere on the earth. By processing signals from the satellites, a GPS receiver can determine its position with an uncertainty of $< 10\text{m}$. GPS, well known as a worldwide positioning system, has also become the primary system for distributing time and frequency. As we know, each satellite carries either rubidium or cesium oscillators, or a combination of both. They are steered from USDOD ground stations and are referenced to what is known as Coordinated Universal Time (UTC), a worldwide basis for measuring time, maintained by the United States Naval Observatory (USNO) in Washington DC. This allows GPS users to measure UTC through solving for GPS time in equations and using broadcasting time parameter ^[2]. Thus GPS receiver can provide one pulse per second (1PPS) signal synchronized to UTC. Before we discuss the details of calibration, let's first take a look at the accuracies of the GPS System. First of all, the

system guarantees that the accuracy of the reference 1PPS will be within 100 nanoseconds to UTC under normal conditions, and within 300 nanoseconds under the conditions of Selective Availability (SA). GPS receivers are fixtures in calibrations. They make it possible to calibrate in any facility that can place an antenna outdoors for line-of-sight reception of GPS satellites. Through the use of the GPS system, we now have a worldwide reference that can be affordable. Therefore, this is a better and more cost-effective way for calibration.

COMMON FREQUENCY CALIBRATION METHODS

The comparison is made between the device adjusted and a precision frequency source. We call it frequency calibration. All secondary frequency sources require periodic calibration, usually against local reference standard, for the highest precision against a national reference standard. There are three main frequency calibration methods: frequency counters, time interval counters, phase comparisons^[4].

The frequency counter is widely used, which can be used directly measure the frequency of the signal applied to its input port. This method is very simple. The accuracy depends on the performance of the frequency counter. If it is synchronized by an external reference source, the accuracy and stability can be greatly improved. However, because of the limitation of internal designs of counter, high precision frequency sources cannot be adequately evaluated. Thus the heterodyne technique is applied to frequency measurements. It can significantly improve the resolution of frequency counters.

The time interval method uses a device called a Time Interval Counter (TIC) to measure the time interval between two signals. A TIC has two inputs for electrical signals. One signal starts the counter and the other stops it. If the two signals have the same frequencies, the time interval will not change. If the two signals have different frequencies, the time interval will change, although usually very slowly. By looking at the rate of change, we can calibrate the device. The TIC methods are mainly used as the dual-mixer time-difference technique and the direct time-interval technique. Some interval counters even have limited math ability. However, this level of equipment must have a good internal oscillator and units can be expensive.

The phase comparison used in our calibration circuits is the common use in frequency calibrations, in which two signals are applied to a linear phase comparator. The phase difference is the number of an external frequency source.

MOTOROLA UT ONCORE™ GPS RECEIVER

The GPS signals through ionosphere are very low at the Earth's surface, and below the noise floor. Since they are at such a low power level, GPS signals are susceptible to interference from external sources, such as RF interference that may cause the GPS receiver to lose lock on the GPS signal.

Motorola UT Oncore has many improvements aimed at the precise timing applications^{[2][3]}. Many

precise timing GPS installations require locating the GPS antenna at close range of radiating antennas such as cellular telephone, paging, or other wireless communication systems. Some of these transmitters may randomly cause the GPS receivers to lose lock on tracked satellites. This can be very disconcerting to the timing user since the system must rely on clock coasting' until the satellite signals are reacquired. GPS receiver selectivity, or the ability to select only the GPS band of information and reject all the other signals, is an important feature for GPS receivers, especially in cases such as those often encountered in timing applications. To reduce the risk of unintentional jamming from high power out-of-band signals causing dropouts, additional filtering has been added to the UT Oncore. As the result, the selectivity of GPS receivers is greatly improved.

Motorola has developed an innovative software technique to further improve the Adaptive Tracking Loops jamming immunity of the UT Oncore receiver. The technique takes advantage of the fact that the receiver is not moving for precise timing applications. In mobile applications, the receivers must have wide tracking loops to track satellites in the maximum expected vehicle acceleration and velocity. When the GPS receiver is stationary, the tracking loops do not need to be such wide in order to track the satellites. In the UT Oncore 2.x firmware, the satellite tracking loop is narrowed once the receiver has acquired the satellites and reached a steady state. This adaptive approach allows the tracking loops to be narrowed for maximum interference rejection.

Additionally, Time Receiver Autonomous Integrity Monitoring (RAIM) is an algorithm in the Oncore timing GPS receivers that uses redundant satellite measurements to confirm the integrity of the timing solution.

FRQUENCY CALIBRATION CIRCUITS DESCRIPTION

As shown in the block diagram of figure2, calibration circuits include an OCXO, a frequency generator, a Motorola UT Oncore timing GPS receiver, a phase measurement, and a PCI bus controller.

An oven-controlled oscillator has a stable, high performance, which is used as the frequency reference by a frequency generator and a local oscillator, and widely used in high stability test equipments. A frequency generator and a local oscillator are direct digital synthesizers AD9852. The AD9852 digital synthesizer is a highly integrated device that uses advanced DDS technology, coupled with an internal high-speed, high-performance D/A converter to form a digitally programmable agile synthesizer function. When referenced to an accurate clock source, the AD9852 generates a highly stable, frequency, phase, amplitude programmable cosine output that can be used as an agile L.O. in communications, radar, and many other applications. The AD9852's innovative high-speed DDS core provides 48-bit frequency resolution (1 micro Hertz tuning resolution with 300 MHz SYSCLK)

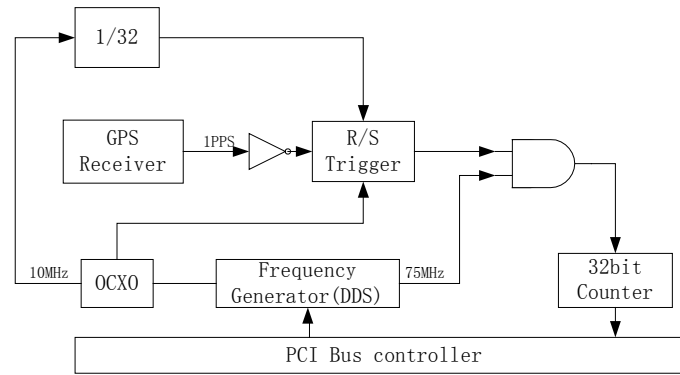

Figure 2 Block diagram of the GPS-based Frequency calibration

To lessen the ambiguity, phase differences between 1PPS GPS pulses and the output signals from the OCXO are not directly measured, but those between 1PPS pulses and divided the OCXO outputs^[5]. Therefore, after amplification and shaping circuits, the 10MHz signal from the OCXO is divided by 32 to produce an output of 312.5KHz. The phase difference is measured by counting the number of the 75MHz signal pulses from the frequency generator. After that, the phase difference can be read through PCI bus controller and kept in a file by the computer. If the phase difference is constant, we know that the OCXO is synchronized to the GPS atomic clock.

As the calibration device is built in the transmission system, the computer monitors the phase difference between GPS and the OCXO through PCI bus and responds appropriately during calibration. If the phase difference begins to drift, the computer must correct the frequency generator. As the differences between the UT Oncore 1PPS outputs in position hold mode and Cesium standard output show the sawtooth behavior, which is Gaussian distribution, a long-term average of the pulse output is not biased by the sawtooth error. Thus we average lots of phase differences to eliminate the sawtooth error.

CONCLUSION

The built-in calibration device makes the Pi-network transmission system calibrated convenient. Thus many quartz crystal manufacturers need not to keep the high precise standard, and save much money and time.

REFERENCES

- (1) B W.Neubig, R Zimmermann, "Recent Advances on the Measurement of Quartz Crystal Units up to 500MHz and above by the Use of a Pi Network with error correction," in IEEE Frequency Control Symposium, in 1989
- (2) J.Blake Bullock, T.Michael King, Howard L.Kennedy, Edward D.Berry, Gregg Zanfino, "Test Results and Analysis of a Low Cost Core GPS Receiver for Time Transfer Applications," in IEEE Frequency Control Symposium, 1997

- (3) Motorola GPS Oncore version5.0 User's Guide.
- (4) Terry N.Osterdock, John A.Kusters, "Using A New GPS Frequency Reference in Frequency Calibration Operations," in IEEE Frequency Control Symposium, in 1993
- (5) Brook Shera, " A GPS-Based Frequency Standard"