

DATA ACQUISITION SYSTEMS FOR AUDIO-FREQUENCY, MECHANICAL-TESTING APPLICATIONS — RECENT DEVELOPMENTS 2001 —

**Strether Smith, Chief Scientist
DSPCon, Inc.
Bridgewater, NJ**

ABSTRACT

The objective of any data acquisition system is to make accurate measurements of physical phenomena. Many of the phenomena to be characterized contain data that is in the audio-frequency range between 0 and 50,000 Hertz. Examples include structural vibration, wind-tunnel measurements, turbine engines and acoustics in air and water. These tests often require a large number of channels and may be very expensive. In some cases, there may be only one opportunity to acquire the data.

This paper describes a testing/measurement philosophy and the use of advances in available hardware/software systems to implement the requirements. Primary emphasis is on robustness (assurance that critical data is properly recorded), measurement/characterization of unexpected results (generated by accidents or unexpected behavior), and test safety (for both the test article and the facility).

Finally, a data acquisition system that encompasses the features discussed is described.

KEY WORDS

Digital Data Acquisition, Mechanical Testing, Acoustic, Vibration

RECENT DEVELOPMENTS IN DATA ACQUISITION SYSTEM TECHNOLOGY

The state of the large-scale data-acquisition system art in 1997 was described in Reference 1. The following paragraphs describe several technologies have become viable (or significantly improved) for real-world data acquisition systems since that time.

“GIGABIT” Networks: Perhaps the most important of these is the development of such high-speed networks as gigabit Ethernet, Firewire, and Fibre Channel. These technologies allow the transfer of multiple channels of audio-frequency data from device to device. These concepts are combined with new disk-storage technologies in the form of RAID and JBOD systems to allow the high-speed storage and retrieval of enormous quantities of data.

At the moment, systems that are based on Fibre Channel offer the most flexibility and highest speeds of the readily-available architectures. Features include:

- >45 million sample/second data transfers.
- Up to 10 kilometer point-to-point transmission.
- Multiple, backward-compatible, communication protocols.
- Support for huge, high-speed, disk farms
- Support by a large number of vendors.

Analog-to-Digital Conversion Technology: During this period Sigma Delta ($\Sigma\Delta$) conversion systems have been developed to a high art and are almost universally accepted for audio-frequency applications. These systems offer:

- Bandwidths of over 50 kHz.
- Almost-perfect alias-error rejection.
- Flat response and constant delay (linear phase).
- Dynamic range of over 85dB.

This combination of features makes these systems almost perfect for measurements in the audio frequency range. The “digital” technology is so good that the onus is placed entirely on the quality of the analog components (transducers, wiring, signal conditioners, and amplifiers) that precede it.

DSP-based Calculation Systems: Improvements in performance and data accessibility allow very powerful run-time calculations. Examples include:

- Inspection of every data point for violation of level parameters.
 - Alarm generation based on logical combinations of violations.
- Large-array spectrum calculations to provide fine frequency resolution.

These capabilities greatly expand the available options for test monitoring for safety and display.

PC-based Calculation and Display Systems: Modern Intel and Intel-compatible machines offer excellent calculation and display capabilities.

- The requirements of PC gamers have produced capabilities that provide very powerful scientific computations and displays.
- The systems are very low in cost and are improving rapidly.

For instance, a modern Pentium-based machine can do a 1024K Fast Fourier Transform in about 1 second...a task that took minutes on a midi computer just a few years ago.

BASIC TESTING PHILOSOPHY

The objective of any experiment is to record an accurate representation of the phenomena being studied. Fundamental components of this objective are:

Get any data at all. This obvious objective is missed more often than most investigators would like to admit. It is essential that the instrumentation and recording system operation be verified before the test. Strategies that improve the probability of success include:

- Use continuous recording that is started and verified before the test instead of triggered recording.
- Assure that the complete recording path is operational before the test starts. This is accomplished by performing read-after-write data verification.

Get data that is not wrong (note the choice of words). There are a number of possibilities here:

- Systems that do not have adequate alias-signal rejection will produce corrupt data sets. Worse, the fact that the results are corrupt usually cannot be detected.
- If the system is not adequately protected from errors caused by induced voltages the results will be compromised. A particularly bad example occurs when the induced error is coherent with the phenomenon being measured. An example is errors caused by the fields of the electrodynamic shaker in a vibration test. The error signals will look exactly like the response from the vibration transducer and cannot be rejected once the data are recorded.
- Some data acquisition architectures produce erroneous (but “good-looking”) data when transducers are incorrectly connected or not connected at all.
- Some architectures are susceptible to channel scrambling, thus causing data to be assigned to the wrong location.

Obviously, these possibilities are not acceptable.

Get data that is right!: Unfortunately, this is not as simple as it seems. In addition to the real errors that occur in any measurement process, the measurement system will (not may) distort the data. For example, Figure 1 shows three time histories that were processed to emulate three alias-protection strategies that are used on commercially-available data acquisition systems. It can be seen that there is a significant difference between them. Which one is correct? None of them.

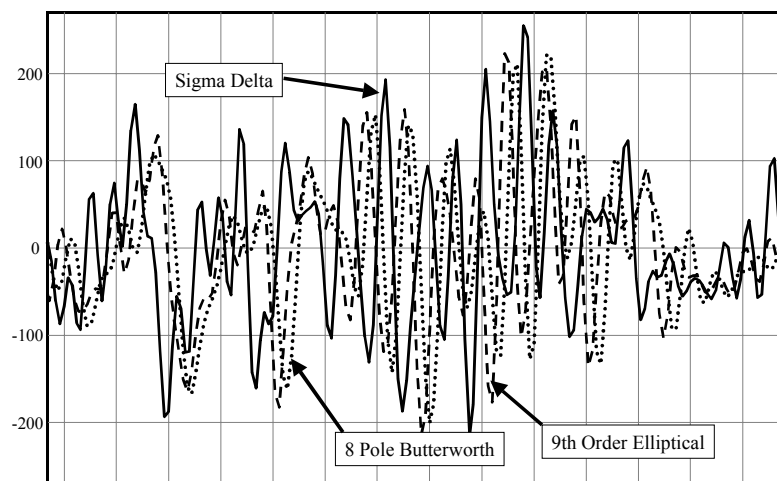

Figure 1—Transient Data Acquired by Different Data Acquisition Systems

The point here is that the best we can do is to record data that is consistent. A good system will measure individual data points that are linear and repeatable to within 1% of full scale over the full bandwidth of the system. Then, if necessary, analytical tools can be used to modify the data to make it agree with other systems. [Reference 1].

Beyond this consideration, it is critical that errors that cannot be accounted for by distortion analysis/correction are minimized.

The worst of these is aliasing; an error that cannot be removed after the measurement is made and often cannot be recognized. Properly implemented sigma-delta-based data acquisition systems attenuate these errors to values below the system measurement resolution.

Noise and signal corruption due to external magnetic and electric fields must be minimized. Proper amplifier, wiring, and grounding techniques are required to take advantage of the concepts discussed here.

Be able to record data that is significantly larger than what is expected. In a large number of tests, the objective is to find behavior that is not expected (otherwise, why is the test conducted?). An unacceptable result is that large responses saturate the instrumentation and/or recording system. It is these measurements that we really care about.

The solution is to take advantage of the dynamic range of available instrumentation and data acquisition systems. Piezoelectric transducers, the devices used most commonly in this frequency range, provide a dynamic range (Full scale/Smallest Detectable Signal) in excess of 90 dB. This, combined with a good signal-conditioning/data-acquisition system, will provide a system dynamic range of over 80dB (10,000/1).

This allows a very conservative choice of system range (gains). It is perfectly reasonable to set the full-scale range to 100 times the expected value. Then, with the available dynamic range, a measurement that is 0.1% of expected value can still be resolved. Most important, however, is that the unexpected, high-level responses will be recorded.

Monitor the test data and display and react to the results. This has two facets.

- Data viewing for sanity: This usually takes the form of multi-channel, graphic displays in time- or spectral-domain format. The challenge here is to present huge amounts of data in a format that the test engineer can understand and react to if there are unexpected results.

Modern systems offer the capability of multiple screens, each with 20 or more channels displayed in a variety of formats. The challenge is not getting the data to the display. The problem is making it understandable.

An important recent development is the capability of performing high-resolution spectral calculations at run-time speeds. For example, characterization of structural motions often requires a spectral resolution of less than 1 Hz. When data is being acquired at 100,000 samples/second a 128K FFT is required.

- Automatic anomaly checking and reaction: Modern DSP technology allows the inspection of every data point and comparison with pre-selected warning and error levels at an aggregate rate of millions of samples/second. The detected anomalies can be combined logically to generate messages and/or shutdown commands.

Data Traceability: As experiments become more complex and data acquisition systems become larger (i.e., more channels) documentation of the measurement process becomes more critical. Part of the problem is that, after the data set is reduced to parameters that are useful for engineering analysis (Power Spectral Density, Transfer Function, Shock Response Spectrum...), its pedigree is normally lost. Information like transducer type, calibration, alias-protection strategy and other parameters can (and do) affect the data, and the same test performed with different, equally-viable instrumentation/acquisition systems will produce results that are significantly different.

It is essential that a complete description of the data sources, paths, and analysis processes be included with any data presentation. Interpretation and validation of the results are completely dependent on the data's heritage.

SPECIAL TEST CASE CONSIDERATIONS

Some testing activities are potentially prone to accidents. One example is laboratory structural-dynamic testing where sensitive specimens (e.g., spacecraft) are tested on equipment (e.g., electrodynamic shakers) that, if not properly controlled, can damage the specimen and/or the facility. Accidents can also occur when the specimen is being moved or when there is an incident during instrument installation.

Traditionally, in these cases, a “doomsday” recorder has been used. This might have been a magnetic tape system capable of recording critical channels over long periods of time.

The systems described here have the capability of recording all of the channels continuously at a high sample rate in a rotating buffer. The principle, which emulates a transient recorder with a very-large memory, is shown in Figure 2.

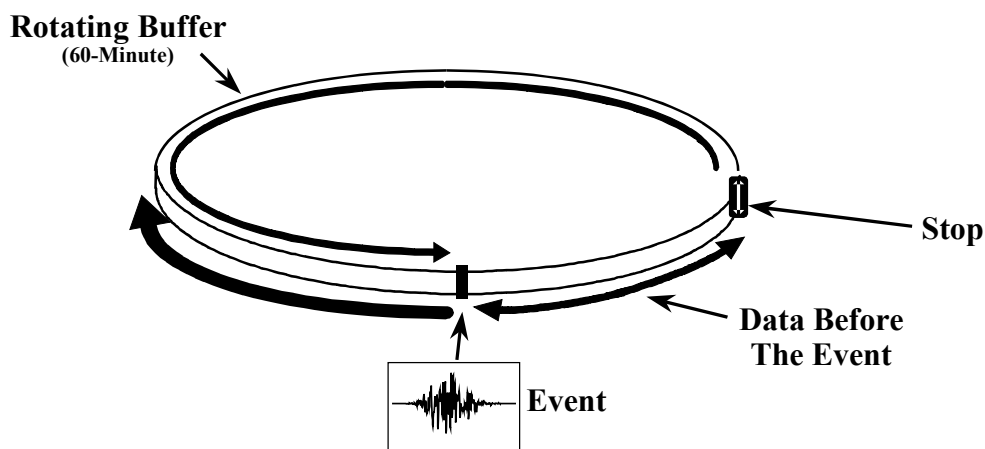

Figure 2–The Rotating-Buffer “Doomsday” Recorder

The recording system is run any time that transducers are attached and that there is any possibility of specimen damage (perhaps, all the time). If an accident occurs, either an event trigger or an operator stops the acquisition before the rotating buffer is written over (60 minutes in the example pictured) and the anomaly can be examined from the acquired data.

The critical determination is whether the specimen was overstressed (or whatever criterion is appropriate) during the accident. To do this, the range of the measurement system must be scaled in such a way that motions that will damage the specimen are within the full-scale range. This requires the high-dynamic-range instrumentation/recording system discussed earlier.

SYSTEM ARCHITECTURES

Figure 3 shows the architecture of a typical 64-channel DSPCon system. Figure 4 shows a multiple Data Station/Multiple Work Station system architecture that would be used for large-scale testing. Systems with up to 16 data stations (1024 channels) are reasonable.

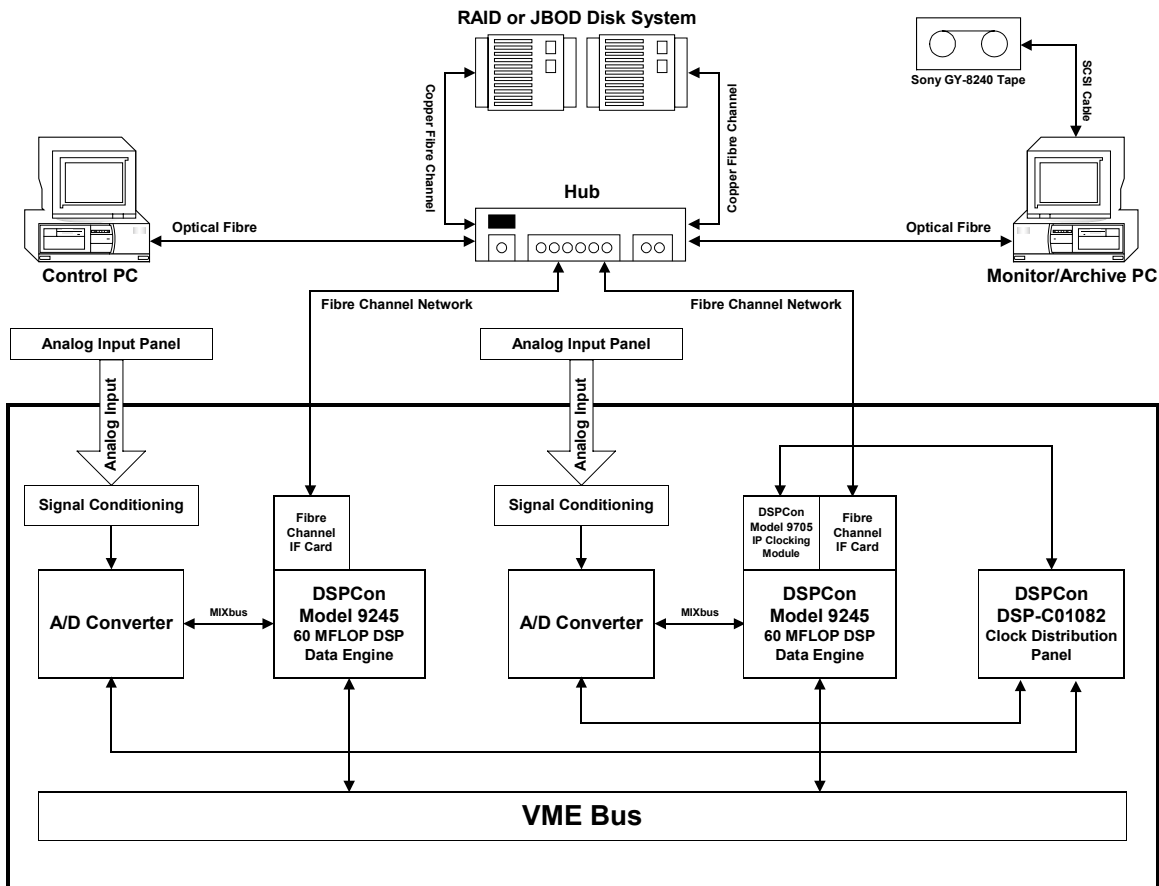

Figure 3—A Typical Fibre Channel-based System for Medium-sized Applications

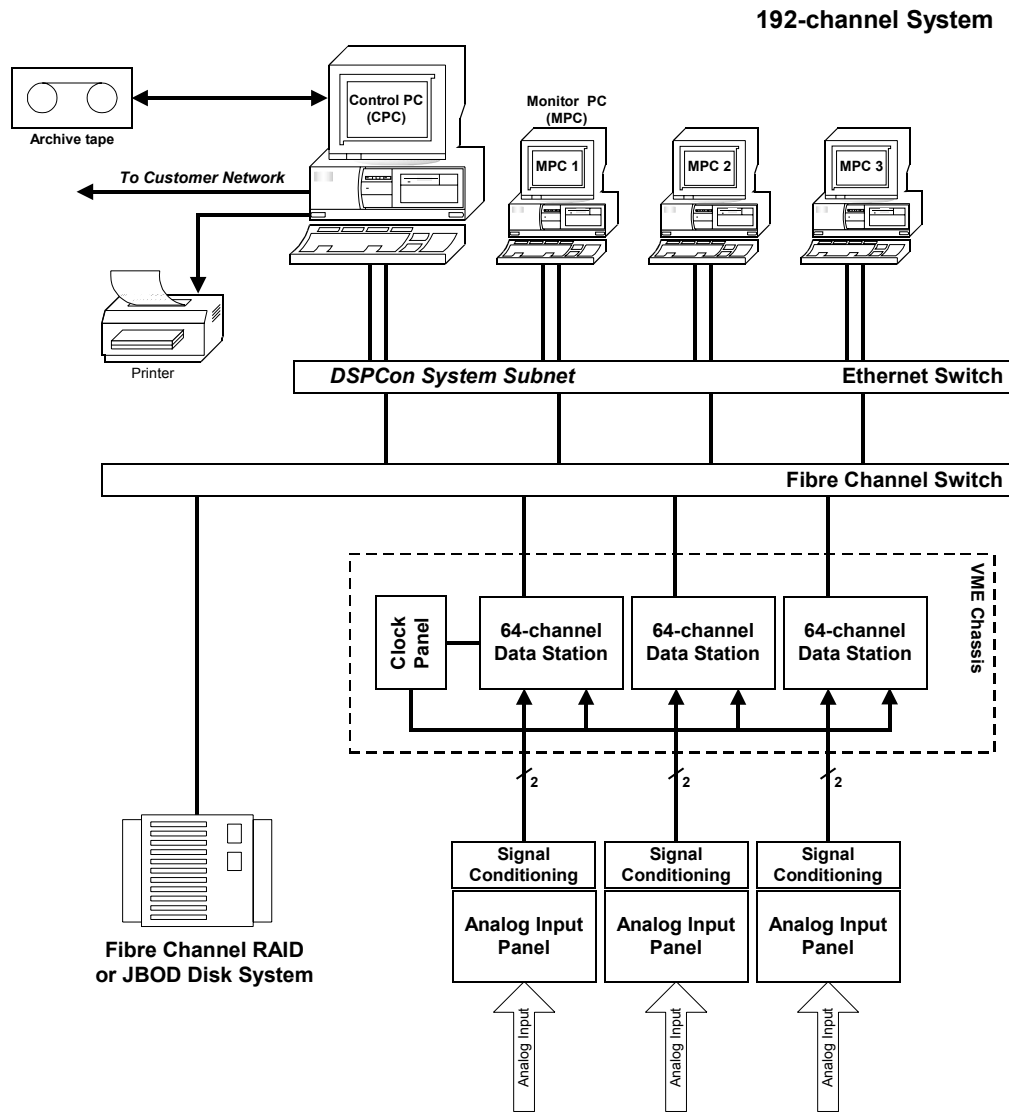

Figure 4—Multiple Data Stations Provide Up to 1024 Channels

Each Data Station includes:

Signal Conditioning: The analog front end of the system has the following features:

- Each channel supports both voltage and “Internal Electronic” measurements.
 - Voltage measurements are made in either single-ended or differential mode.
 - AC/DC Coupling
 - DC coupling:
 - CMMR >80 dB (differential)
 - AC coupling:
 - Rejects a minimum of 20 volts DC offset at any gain.

- CMMR >70 dB (differential)
- Internal Electronic measurements have:
 - Programmable current excitation from 2 to 20 mA.
 - Bias test (Validity indicated on the front panel and value transmitted to the computer)
- Programmable Gain to provide full-scale ranges of $\pm 10, 5, 2, 1, .5, .2 \dots 0.01$ volts.
- Buffered Analog Outputs for all channels are available on the front panel.
- All channels are monitored for saturation by testing the positive and negative excursions of the input amplifier for violations of a programmed level (nominally +9.95 volts). Violations are continuously sensed by the system and are “announced” and logged.
- All functions are programmable on an individual-channel basis.
- All inputs are fuse protected.

Analog-to-Digital Conversion: The system uses Sigma Delta technology to provide:

- Bandwidth up to 58 kHz (at 130,000 samples/channel/second).
- Almost-perfect alias-error protection.
- Flat Pass Band (+1% from DC to the Bandwidth)
- Simultaneous acquisition of all channels (± 10 nS).
- Linear Phase/Constant Delay.
- Programmable sample rates from 1K to 130K Samples/second with resolution of $<.001$ samples/second.

Overall Measurement Performance: These systems have been demonstrated to provide a dynamic range of over 80 dB in laboratory conditions using real transducers on 200 feet of cable.

Data Storage: A JBOD or RAID System with over 50 Gbytes for each 64-channel system. This provides more than 60 minutes of data storage at 100,000 samples/second and can be readily expanded to 10 times the volume, if appropriate.

THE PIRANHA™ SOFTWARE SYSTEM

This system provides a complete test setup, data acquisition/storage, data analysis, and data archiving environment for a variety of experimental regimens. It has been designed for use in large-scale testing environments in which tests with hundreds of channels are the norm. It is comprised of three primary sections.

The Three-tier Database manages the measurement devices in the facility and provides the tools necessary to set up the data acquisition and analysis for the test. It is made up of three components:

- Catalog – A generic description of the available transducers
- Inventory – Detailed description of the properties of individual transducers.
- Setup – Defines a test by drawing on the Catalog and Inventory for transducer information.

The Run Time System operates in two modes:

- Rotating Buffer (Monitor or Doomsday Recorder) with a loop time that is as large as the available disk space. The acquisition can be stopped at any time and the data viewed to inspect en experimental anomaly.
- Defined acquisition period in which a normal data storage is made for a predetermined period. It can be stopped early by operator command.

During both modes the following tasks are performed:

- Disk read-after-write data verification.
- Runtime Display: On the control terminal and each monitor terminal
 - Up to 20 frames with 1 channel/frame are displayed.
 - Each channel is displayed in time, spectral, or Lissajous format
 - Frames are updated 5 times/second or at the data buffer rate, whichever is slower.
- Runtime Calculation
 - All acquired data is checked against warning and error levels.
 - Spectral calculations with up to 128K FFTs are performed on selected channels.

The product of the acquisition process is a set of data files known as *CATS Files*. There is a file for each channel and, in addition to the data stored in raw A/D counts, it contains a complete pedigree of the data including all of the information entered into the Setup database.

The Post Processor System provides data viewing and analysis facilities for data stored in CATS files. Presently available processors include:

- Data Viewer: A tool for the examination of data in time-history and spectral format.
- Narrowband Processor: An analysis system for characterization of data in FFT-based spectral form. FFTs of up to 1 Megapoint are used to calculate Power Spectral Density or Fourier-Spectrum magnitude.
- Octave-band Processor: Analyzes the data with FFT-based, ANSI-compliant, or IEC-standard 1/N-octave filters with 1/1, 1/3, 1/6, 1/12, and 1/24 octave-spacing/bandwidth.
- Shock Response Spectrum (SRS) Analysis Processor: Performs a Smallwood-Algorithm SRS. Allows data normalization as described in Reference 2.
- Rotating Machinery Processor: Performs time- and spectral-domain analysis associated with tachometer signals.

This combination of hardware and software systems provides a robust data-acquisition and analysis capability for large-scale structural vibration, wind tunnel, turbine engine and acoustic testing.

CONCLUSIONS

The past five years have produced several significant advances in A/D conversion, networking, storage, computation, and display technologies that might be used in audio-frequency data acquisition systems. This paper has discussed the application of these advances to produce more flexible and robust systems that provide a significantly-improved probability of making meaningful measurements in critical tests.

REFERENCES

- 1) Smith, Strether, Katz, Steve, Hollowell, Bill, and Olson, Eric, “Developments in Digital Data Acquisition/Analysis System Technology for Large-Scale, Structural-Dynamic Testing Facilities”, Sound and Vibration Magazine, pp. 18-22. April 1998, (Also published in the Proceedings of the 68th Shock and Vibration Symposium, October 1997).
- 2) Smith, Strether, “Structural-Dynamic Testing Standards—Data Normalization—Problems and Options—”. Normalization Seminar, available for download from www.dspcon.com (Normalization Seminar.pdf).