

RESEARCH ARTICLE | APRIL 27 2023

A quick-release hanging hook design and 3D printing

Desinta Dewi Ramadani; Mohammad Bayu Nur Akbar; Putri Angelica; Kushendarsyah Saptaji ; Cho Lik Chan; Farid Triawan



AIP Conf. Proc. 2646, 050009 (2023)

<https://doi.org/10.1063/5.0112706>



Boost Your Optics and Photonics Measurements

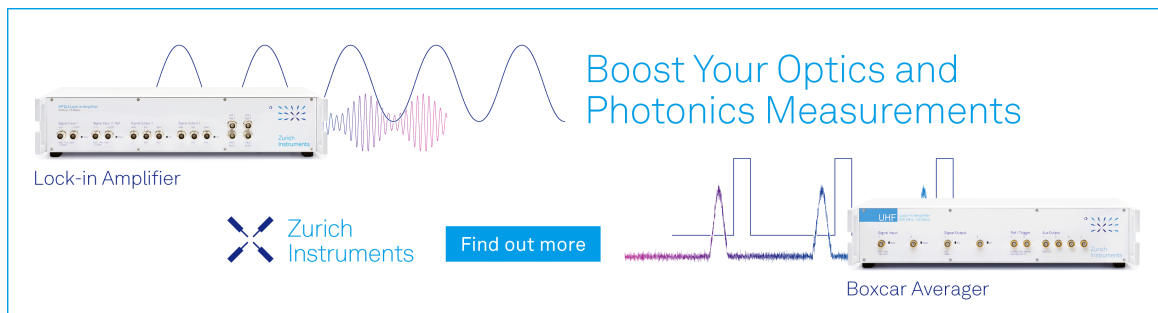

Lock-in Amplifier



Find out more

Boxcar Averager

A Quick-Release Hanging Hook Design and 3D Printing

Desinta Dewi Ramadani^{1, 2}, Mohammad Bayu Nur Akbar^{1, 2}, Putri Angelica^{1, 2},
Kushendarsyah Saptaji^{1, a)}, Cho Lik Chan² and Farid Triawan¹

¹*Department of Mechanical Engineering, Faculty of Engineering and Technology, Sampoerna University, Jakarta 12780, Indonesia*

²*Department of Aerospace and Mechanical Engineering, The University of Arizona, Tucson, AZ, 85721, USA*

^{a)} Corresponding author: kushendarsyah@sampoernauniversity.ac.id

Abstract. Innovative and efficient are the goal of all products made by humans. In addition to innovative designs, the ease with which users can use the product is an essential aspect of a product design. This paper reports the work of a group of undergraduate student project in additive manufacturing course. The aim of the project is to produce a hook prototype that can be used on a pegboard located at the ceiling. The hook is expected can be installed and removed easily from the bottom of the pegboard with hole diameter of 12.7 mm and thickness of 6.35 mm and able to carry a 7 kg load. In this paper, the hook is designed and simulated using SolidWorks software, printed using the FDM 3D printing machine, and tested with a 7 kg hanging load. The finite element simulation shows the proposed design is able to hold the required 7 kg load. The ease installation and removal of the 3D printed hanging hook is also can be fulfilled. The finite element simulation is also validated by applying 7 kg load onto the hanging hook. Hence the proposed design can accomplish the requirements of the project.

INTRODUCTION

The demand of additive manufacturing (AM) or 3D printing as an advanced manufacturing process in various applications is increasing. Additive manufacturing is one of the key technologies in industrial revolution 4.0 [1]. Hence additive manufacturing course is being taught in the university level in order to equip students with the knowledge about additive manufacturing. One of the 3D printing applications is in the production of daily equipment such as a hook. The hook is a necessity that is often used in many places. Hook has a very broad application. Thus, many engineers try to develop hook design that involves many features such as a quick-release mechanism. A quick-release hook design mechanism was applied on the lifeboat and offshore rig [2], space application [3], and chain or metal rope connector [4]. Quick release mechanism is usually defined as the system that can be easily installed or removed within 30-60 seconds [2,5]. The purpose of this paper is to design a hook with a quick-release mechanism so that it can be easily installed and removed by the user.

This project is a final project in the Additive Manufacturing course in Mechanical Engineering program Sampoerna University. The project-based learning is in accordance with the Global Scientists and Engineers Program (GSEP) curriculum, which offers students the opportunity to design their own coursework with consultation with faculty members [6]. In this project, a group consists of three students was required to propose a quick release hanging hook design and discuss with their lecturer. The hook design must be able to be attached to a horizontal pegboard with a hole diameter of 12.7 mm and a thickness of 6.35 mm. The quick release hanging hook must be easily to be installed and removed from the pegboard. The proposed hook design was fabricated by a 3D printing machine. In addition, the hanging hook must be able to hold a mass of 7 kg.

METHODOLOGY

Designing Process

The designing process is conducted to create the computer aided design (CAD) file of the hook using SolidWorks software. The hanging hook design is required to fulfill some requirements such as easy to install and remove from horizontal pegboard with dimension of hole diameter 12.7 mm and thickness 6.35 mm and able to hold a mass of 7 kg.

Finite Element Analysis

The finite element analysis is conducted on the proposed design to ensure that it can hold the required load which is 7 kg [7]. The analysis is conducted using SolidWorks software. Finite element analysis is common tool to optimize geometries such as honeycomb structure [8] and to simulate machining process [9]. The static finite element analysis is conducted by giving a 7 kg load onto the hanging part of the hook and a constraint is applied at the top section of the hook. The material used for the finite element analysis is similar to that used in 3D printing process.

Fabrication Using 3D Printing Process

The 3D printer used is Anycubic i3 Mega which is a fused deposition modelling (FDM) type. Polylactic acid (PLA) is selected as the filament for printing the design. The material properties of PLA are shown in Table 1. PLA is selected due to its strength and ease to be altered to improve the properties [10].

TABLE 1. Material properties of PLA filament [11]

Properties	Values
Hardness	59
Tensile Strength	27-35 MPa
Elongation at Break	250 – 320 %
Tensile Modulus	0.520 – 0.75 GPa
Melting Point	110 - 120 °C

In addition, the pegboard for testing the hanging hook is also produced using 3D printing process. The pegboard appearance is shown in Fig. 1.

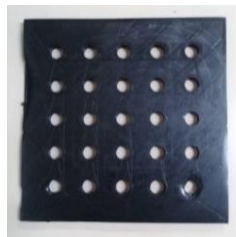

FIGURE 1. The 3D printed pegboard

Installation and Load Test

The testing is conducted manually. There are two tests conducted on the hanging hook prototype. The first test is conducted to check the design of quick-release mechanism. This test is mainly performed to ensure the design can fit the pegboard. The second test is conducted to check the strength of the design. The test is performed by hanging a 7 kg weights into the design that already fit in the pegboard.

RESULTS AND DISCUSSION

Designing Process

The proposed 3D drawing result of a hanging hook with its dimensions is shown in Fig. 2. In this project, two similar hooks are assembled inversely to produce locking system of the hooks.

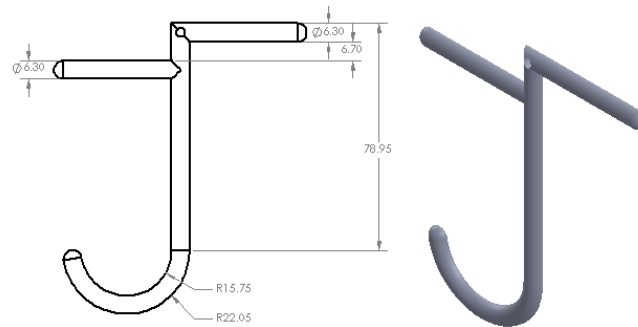

FIGURE 2. 3D drawing of hanging hook part

Figure 3 shows the front view and isometric view of the hanging hook assembly in 3D drawing format. The design consists of two horizontal lines to the right and to the left (see Fig. 2). The horizontal line to the right side is the one that goes across the thickness of pegboard through a hole (the side that cannot be accessed by the user during the installation). The horizontal line to the left is the locking system of the hooks in touch to the bottom side of the pegboard. The cross section of the hanging hook is in semi-circular shape with diameter of 6.3 mm. The total thickness of the assembly is 6.3 mm with the total height of 101 mm and the total length of 88 mm. This dimension is designed to make sure the hanging hook can be installed and removed easily.

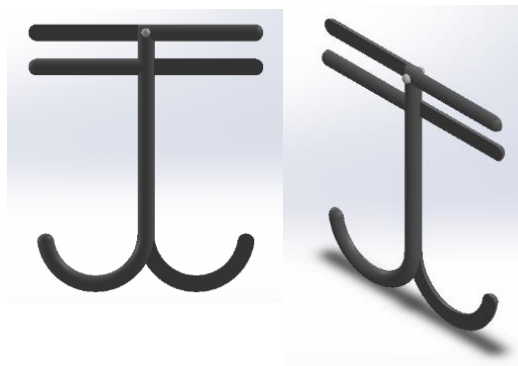

FIGURE 3. 3D drawing of hanging hook assembly (front view) and (isometric view)

Finite Element Analysis

The hook design is then simulated using static finite element analysis available in SolidWorks. The simulation was performed for one hook rather than the assembly set of the proposed hanging hook which consist of two similar hooks. The PLA material properties is not available in Solidworks library hence PLA material is included as a custom material based on the mechanical properties of the PLA as stated in Table 1. The simulations results show that the largest deflection occurred at the lower end of the hook close to the point of applied load (see Fig. 4). The largest deflection is about 20 mm. This result implies that additional hook is needed in order to make less deflection. Hence additional one hook is necessary to be added to distribute the load and to reduce deflection.

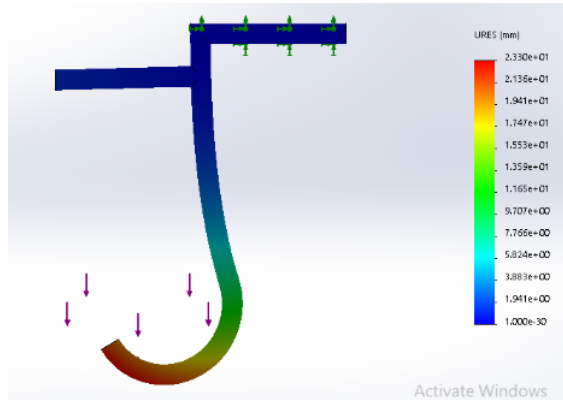

FIGURE 4. Finite element simulation result on a single hook

Fabrication Using 3D Printing Process

In order to perform the 3D printing of the design, the CAD file needs to be converted into GCODE file. An open-source software, Ultimaker Cura, is used to convert the file and to set the printing parameters. Two important parameters for 3D printing process are infill density and layer height. The main printing parameter that is being used is shown in Table 2. The other parameters are kept at the default setting, unless stated. In total, the printing process takes up about 53 minutes.

TABLE 2. Printing parameters used to print the design

Parameter	Values
Layer Height	0.1 mm
Infill Density	100 %
Infill Pattern	Zig Zag
Print Speed	100 mm/s

The result of 3D printing process is shown in Fig. 5. Figure 5 (a) shows the 3D printed result of two single hooks. The dimension is increased approximately by 0.3-0.5 mm for each side due to the tolerance set for 3D printing. Thus, additional filling process needs to be performed. Figure 5 (b) shows the two hooks assembled by a screw. A M1.6 screw is used due to the shrinking of the hole from the initial design.

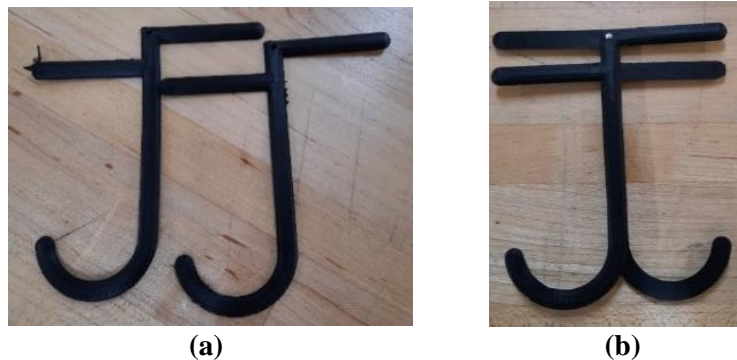

FIGURE 5. 3D printed hooks (a) Two single hooks, (b) Assembly hooks

Installation and Load Test

The first test for the 3D printed hanging hook prototype is to install it into a pegboard. The mechanism is adapted and inspired from scissor mechanism. In order to install the hooks into the pegboard, one hook in the assembly is rotated at about 180° (see Fig. 6). The join section is then inserted into the pegboard hole and the two components are rotated of about 90° into the original assembly (see Fig. 6) to lock the hooks. The removal of the hanging hooks assembly from the pegboard is inverted to the installation step. Hence the quick-release mechanism can be performed in the proposed designed hooks.

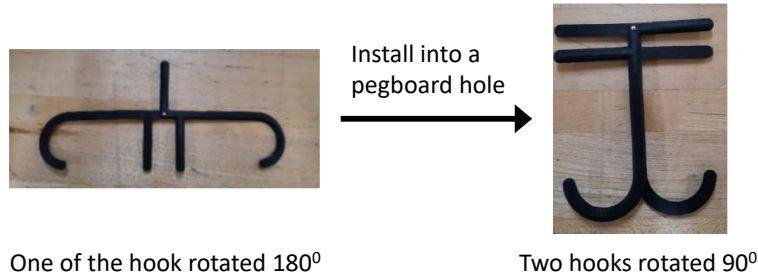

FIGURE 6. Quick release hanging hook mechanism during installation into a pegboard

Figure 7 (a) shows the attached assembly hooks hanging into a pegboard. It shows that the proposed design is successfully fit into a hole of pegboard. However, it required a couple of seconds to install into the pegboard due to the tolerance added in the 3D printing process.

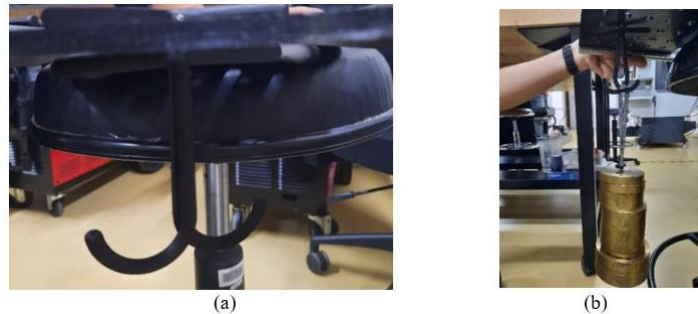

FIGURE 7. Testing the hooks (a) Installation process, (b) Load test process

Subsequently, a load test is performed to demonstrate the design ability to hold minimum load of 7 kg. The load test process is shown in Fig. 7 (b). It can be seen that the design is able to hold 7 kg weights. However, a deflection and bending occurred in the prototype after the load remained for few seconds (see Fig. 8). The load test conforms the finite element simulations results that the hanging hook is able to hold 7 kg load.



FIGURE 8. Bending of the hook after load test

CONCLUSION

In conclusion, the processes to design a hanging hook has been performed and all the design requirements are fulfilled. The hanging hook are proved to be able to be installed and removed easily on a specific pegboard hole dimension and able to hold 7 kg load. The simple mechanism inspired by scissors makes the hanging hook able to be installed or removed from the pegboard quickly. Based on the simulation in SolidWorks and the load experiment using 7 kg weight, the designed hook is strong enough to hold the required load. Therefore, from the simulation and the experiment, it can be concluded that the proposed hook design is successfully fulfil the requirements. However, the prototype still needs some improvements because of slight bend due to the absence of locking system when 7 kg load applied. The locking system can be used to ensure the two hook components more rigid.

ACKNOWLEDGEMENT

We thank to Mr. Ifat for his help in conducting 3D printing process of the samples and conducting load test in Manufacturing Laboratory Sampoerna University.

REFERENCES

1. B. Hadisujoto and R. Wijaya, *Indonesian Journal of Computing, Engineering and Design (IJoCED)* **3**, 46 (2021).
2. C. Goudey, in *Ocean*. 82 (IEEE, 1982), pp. 728–731.
3. W. D. Brame, U.S. Patent No. 4,864,698 (1989).
4. L. Bruzzone, D. Bonatti, G. Berselli, and P. Fanghella, in *Adv. Ital. Mech. Sci.* (Springer, 2017), pp. 523–531.
5. F. Triawan, M. K. Biddinika, S. Hanaoka, and B. A. Budiman, *Indonesian Journal of Computing, Engineering and Design (IJoCED)* **1**, 17 (2019).
6. W. Li, "Development and Evaluation of a Quick Release Posterior Strut Ankle Foot Orthosis," Ph.D. University of Ottawa, 2020.
7. D. Roylance, *Finite Element Analysis* (Department of Materials Science and Engineering, Massachusetts Institute of Technology, Cambridge, 2001).
8. A. J. Octarina, K. Saptaji, and T. Kurniawan, in *IOP Conf. Ser. Mater. Sci. Eng.* (IOP Publishing, 2021), p. 62102.
9. K. Saptaji and S. Subbiah, in *IOP Conf. Ser. Mater. Sci. Eng.* (IOP Publishing, 2016), p. 12005.
10. N. Fatchurrohman, N. N. N. N. Hamdan, M. A. Gebremariam, and K. Saptaji, in *Proc. Int. Manuf. Eng. Conf. Asia Pacific Conf. Manuf. Syst.* (Springer, 2019), pp. 461–465.
11. J. Alan, "PLA Material used in 3D Printing in Materials in solidworks?," [Online] Retrieved from <https://forum.solidworks.com/thread/172306> (2016).